

ELEMENTOS DEL KIT PUERTA

DOOR SET ELEMENTS

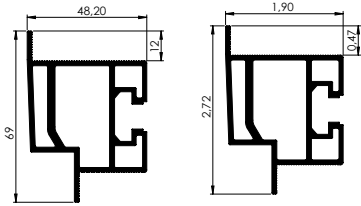

Perfil puerta
Door profile



cinta de doble cara
double side tap

cotas en milímetros

measures in inches

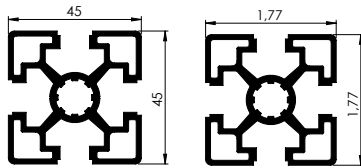

cotas en milímetros

measures in inches

5 Perfil travesaño + 2 conectores por tramo

5 Crossbar aluminium profiles + 2 round head joint for crossbar



Tuercas y tornillos
Nuts and screws
4 Und

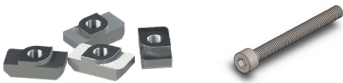

DM tableros 4Uds
DMF Boards 4Uds

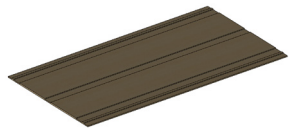

imprimacion, 3 botes por puerta
Pre-paint, 3 canister for door



Cola
Glue



Limpiador
Cleaner

NO INCLUIDO EN EL KIT DE USA
NOT INCLUDED IN USA SET

PASO 1 METER LAS TUERCAS CABEZA MARTILLO EN EL PERFIL CABECERO Y ATORNILLAR EL PRIMER TRAVESAÑO

STEP 1 INTRODUCE THE HAMMER-HEAD NUTS INTO UPPER PROFILE AND SCREW THE CROSSBAR

1

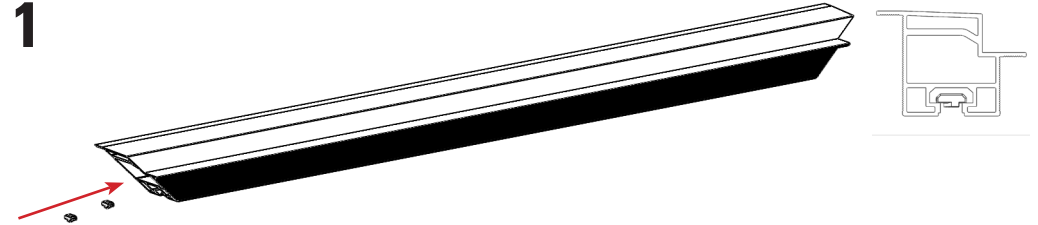

2

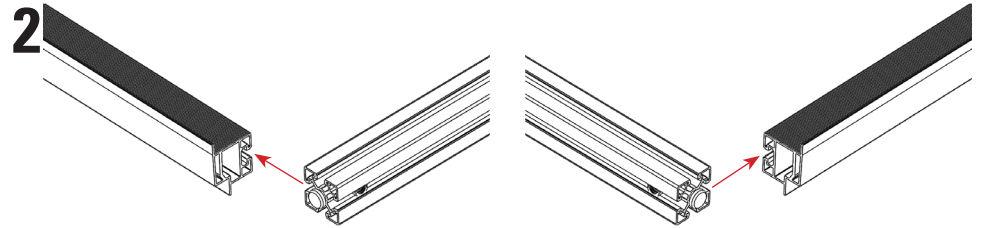

3



4

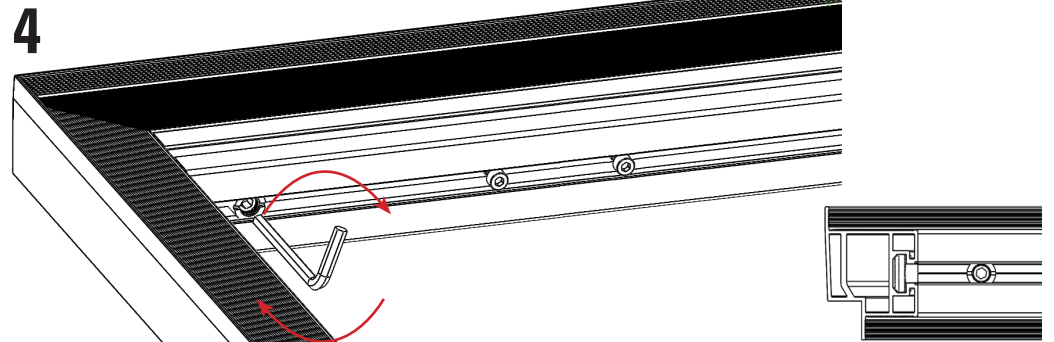

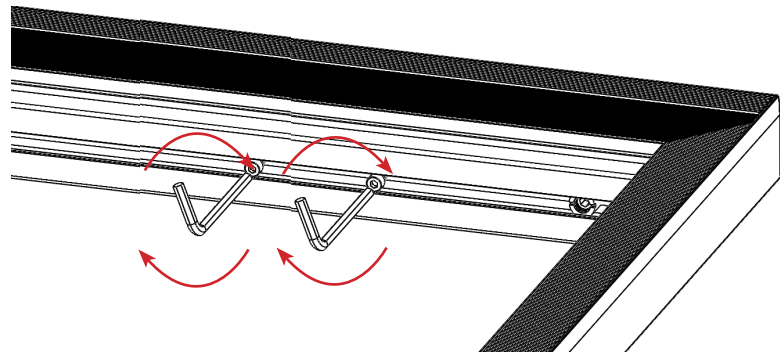
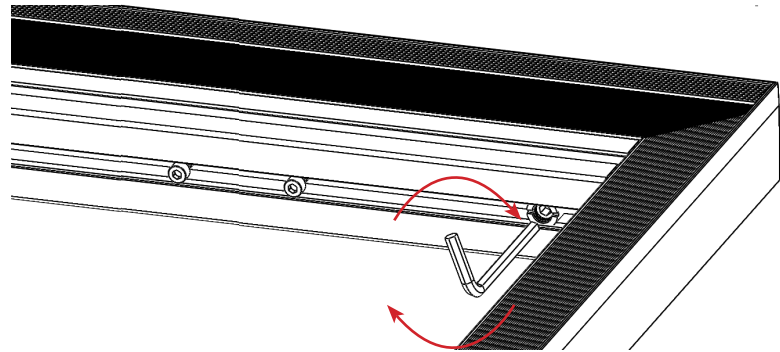
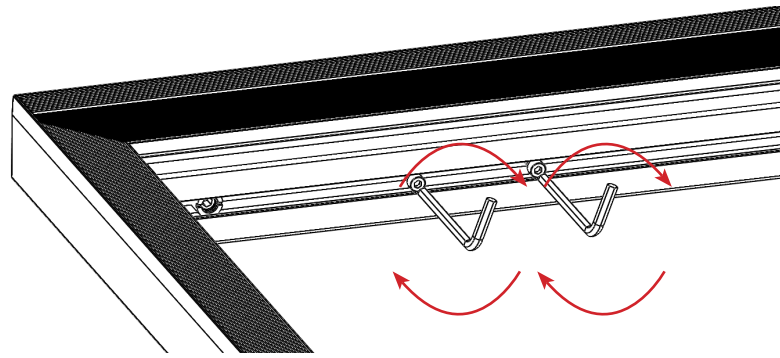

5

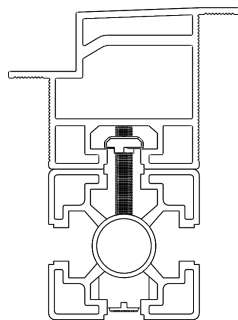

1º TRAVESAÑO DEBE IR ANCLADO A PERFIL CABECERO DE PUERTA
 1º CROSSBAR MUST NEED TO BE UNION ATTACHED TO UPPER HEADER PROFILE

PASO 2 METER SEGUNDO TRAVESAÑO
 STEP 2 PUT THE SECOND CROSSBAR

1

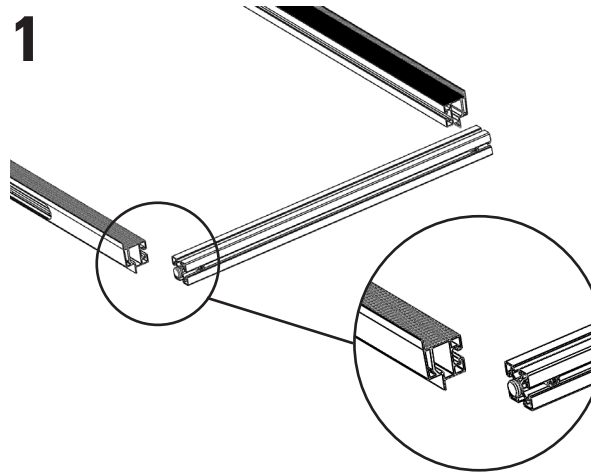

2

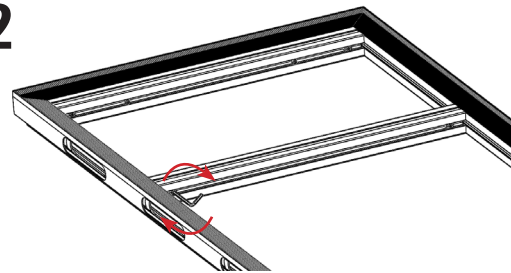

3

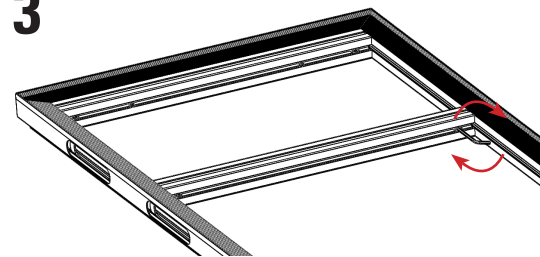

4

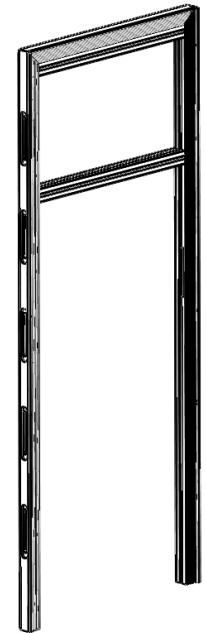

2º, 3º Y 4º TRAVESAÑOS PUEDEN IR A LAS ALTURAS CONSIDERADAS TENIENDO EN CUENTA LOS MECANISMO DEL CIERRAPUERTAS Y LA CAJA DE LA MANILLA
 2º, 3º AND 4º CROSSBARS CAN BE PLACE ANYWHERE THAT DOES NOT INTERFERE WITH MORTICE LOCK AND DOOR LOCKER

ADINOR

PASO 3 METER EL TERCERO TRAVESAÑO

STEP 3 PUT THE THIRD CROSSBAR

1

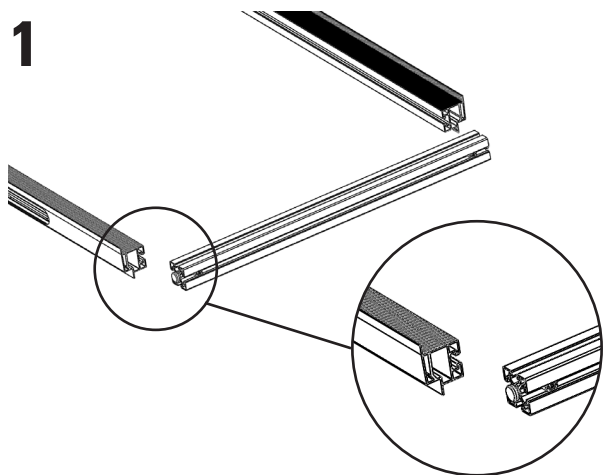

2

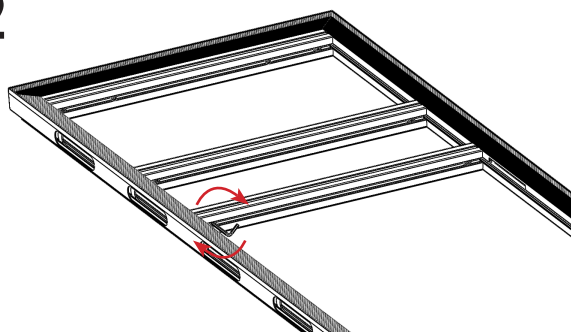

3

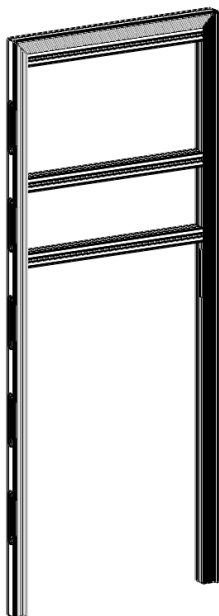
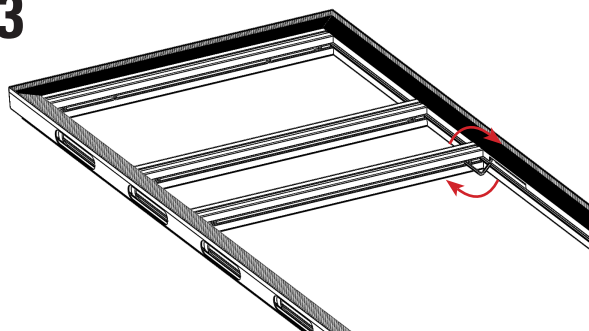

PASO 4 METER EL CUARTO TRAVESAÑO

STEP 4 PUT THE FOURTH CROSSBAR

1

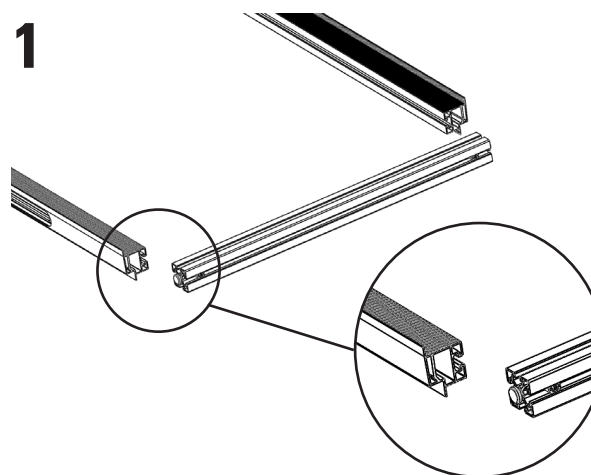

2

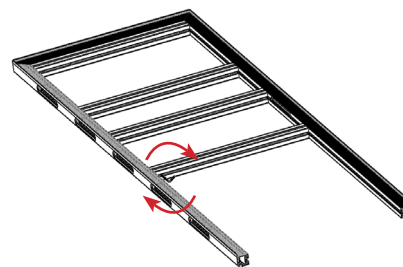

3

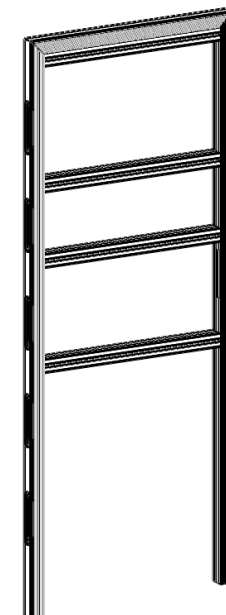
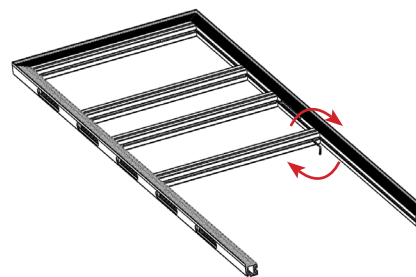

PASO 5 METER EL QUINTO TRAVESAÑO

STEP 5 PUT THE FIFTH CROSSBAR

1

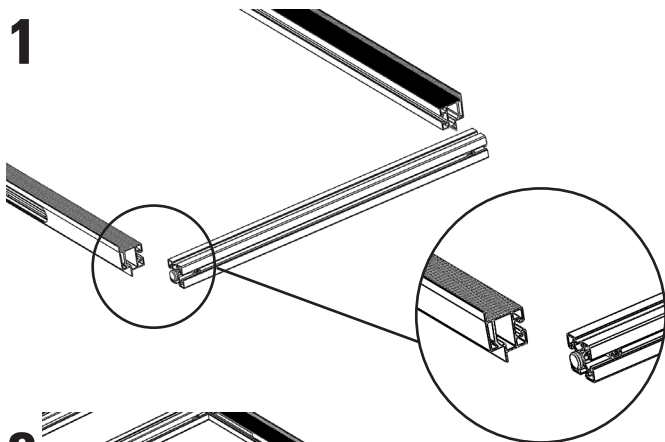

2

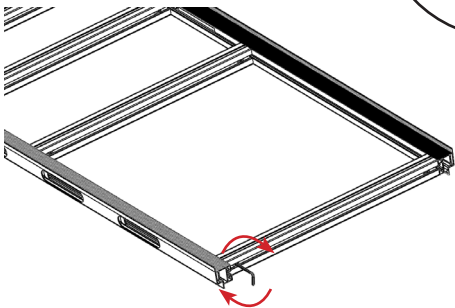

3

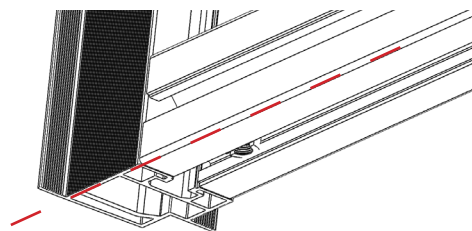
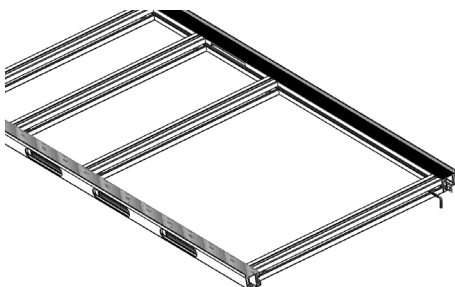
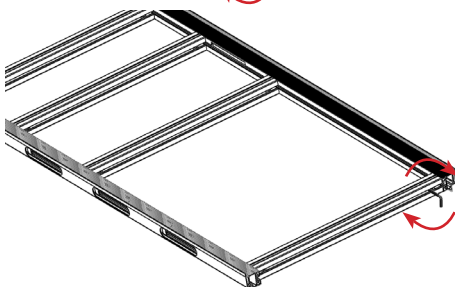

ALINEADO/ ALIGN

PASO 6 ATORNILLAR LOS TABLEROS DE DM A LOS TRAVESAÑOS

STEP 6 SCREW MDF BOARDS TO CROSSBARS

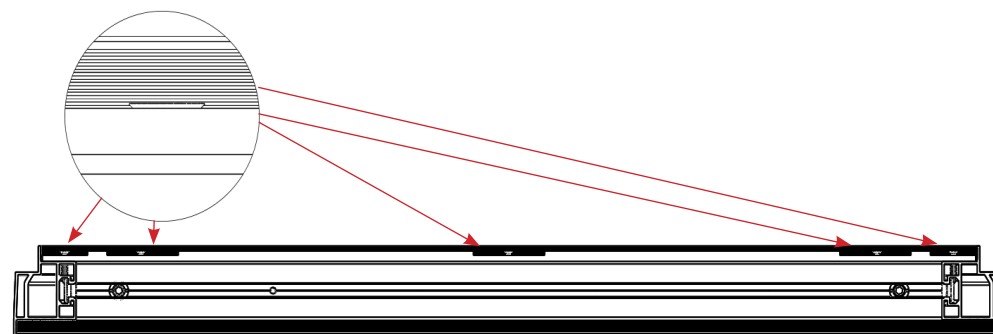
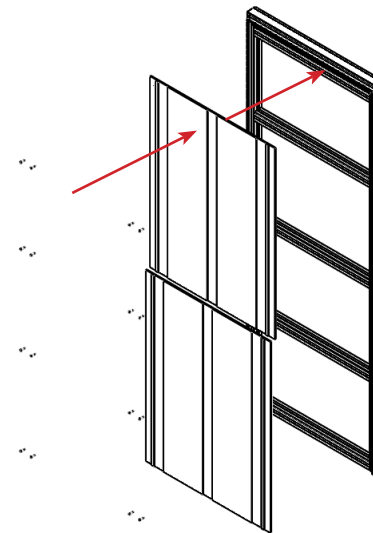

Solo atornillar en los rebajes.
Screw only at recessed areas

Repetir esta operación en la otra cara de la puerta.
Repeat this step in the opposite door side

ADINOR

PASO 7 CON LA AYUDA DE UN RODILLO APLICAR LA IMPRIMACIÓN EN LAS RANURAS
STEP 7 WITH THE HELP OF A PAINT ROLLER, APPLY PRIMER IN THE RECESSED AREAS OF THE MDF BOARDS



INCLUIDO EN EL KIT / NO INCLUIDO
EN EL KIT USA
SET INCLUDED / USA SET NOT
INCLUDED



DEJAR SECAR 50 MINUTOS
LET IT DRY FOR 50 MINUTES

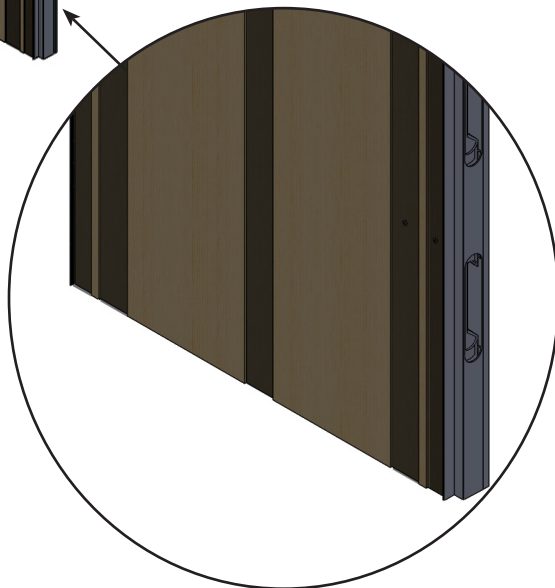

Repetir esta operación en la otra cara de la puerta.
Repeat this step in the opposite door side

PASO 8 PONER CINTA DE DOBLE CARA EN LAS RANURAS DONDE HAY IMPRIMACIÓN
STEP 8 STICK DOUBLE SIDE TAP INSIDE RECESSED AREAS OVER PRIMER

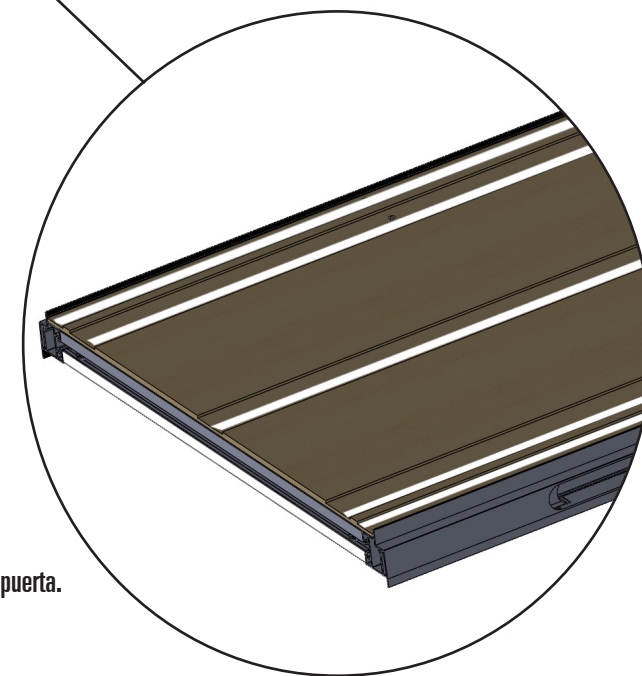
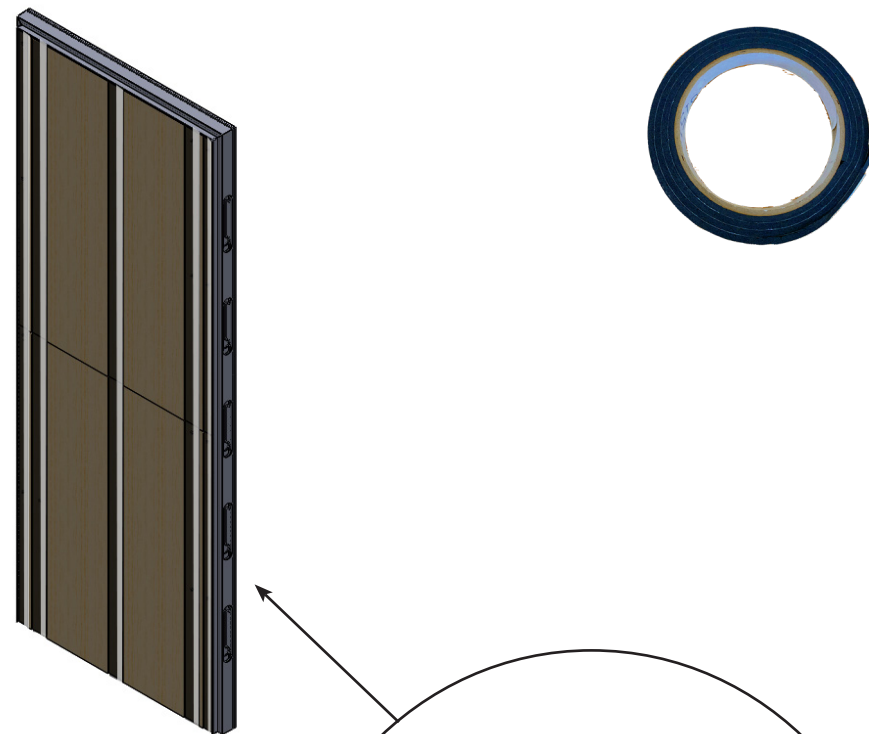

Repetir esta operación en la otra cara de la puerta.
Repeat this step in the opposite door side

PASO 9 ECHAR LA COLA
STEP 9 STICK THE GLUE

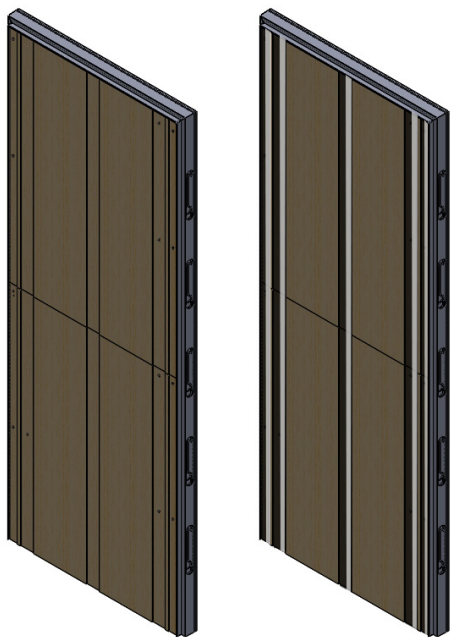

INCLUIDO EN EL KIT / NO INCLUIDO
 EN EL KIT USA
 SET INCLUDED / USA SET NOT
 INCLUDED

ECHAR LA COLA EN EL LADO OPUESTO A
 LA CINTA DE DOBLE CARA DENTRO DE LA
 RANURA
 STICK THE GLUE IN THE OPPOSITE SIDE OF
 THE DOUBLE SIDE TAP, INSIDE THE RECESSED
 AREAS.

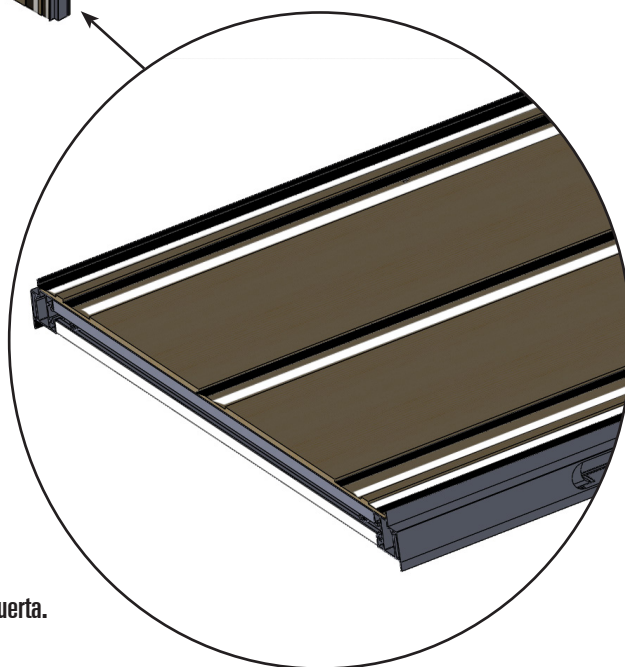

Repetir esta operación en la otra cara de la puerta.
 Repeat this step in the opposite door side

PASO 10 PREPARACIÓN DEL DEKTON ANTES DE PEGARLO
STEP 10 DEKTON PREPARATION BEFORE GLUE IT



INCLUIDO EN EL KIT / NO INCLUIDO
 EN EL KIT USA
 SET INCLUDED / USA SET NOT
 INCLUDED



DEJAR SECAR 5 MINUTOS
 LET IT DRY FOR 5 MINUTES



Limpiar la superficie del
 dektion en la cara mala
 antes del pegado con el
 producto recomendado
 Clean slab back side
 before glued with
 recommended cleanner

PASO 11 PREPARACIÓN HOJA DE PUERTA
STEP 11 DOOR LEAF PREPARATION



Repetir esta operación en la otra cara de la puerta.
 Repeat this step in the opposite door side

PASO 12 PEGAR PLANCHA DE DEKTON STEP 11 GLUE THE TILE

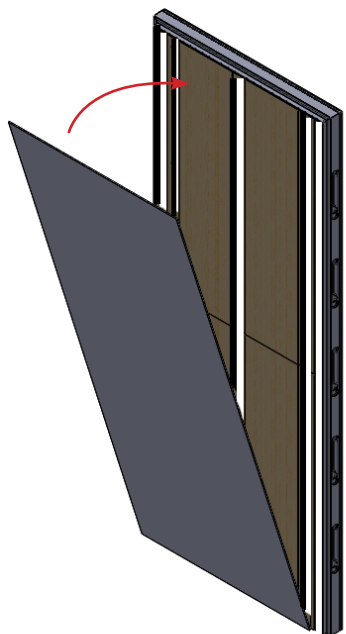

Repetir esta operación en la otra cara de la puerta.
Repeat this step in the opposite door side

PASO 13 MEDIDA PARA TALADRO DE LA MANILLA STEP 12 MEASURE FOR THE HANDLE DRILL

Tal como se puede apreciar en los perfiles verticales de la puerta, estos no son simétricos a ambas caras, ver imagen:

Debido a esto realizamos el agujero de la maneta teniendo en cuenta diferentes medidas según la cara donde taladramos.

Vertical door profiles are not symmetricals in both sides. see the attached image:

Take this fact into account , different measures according to the door side when your drill the handle hole.

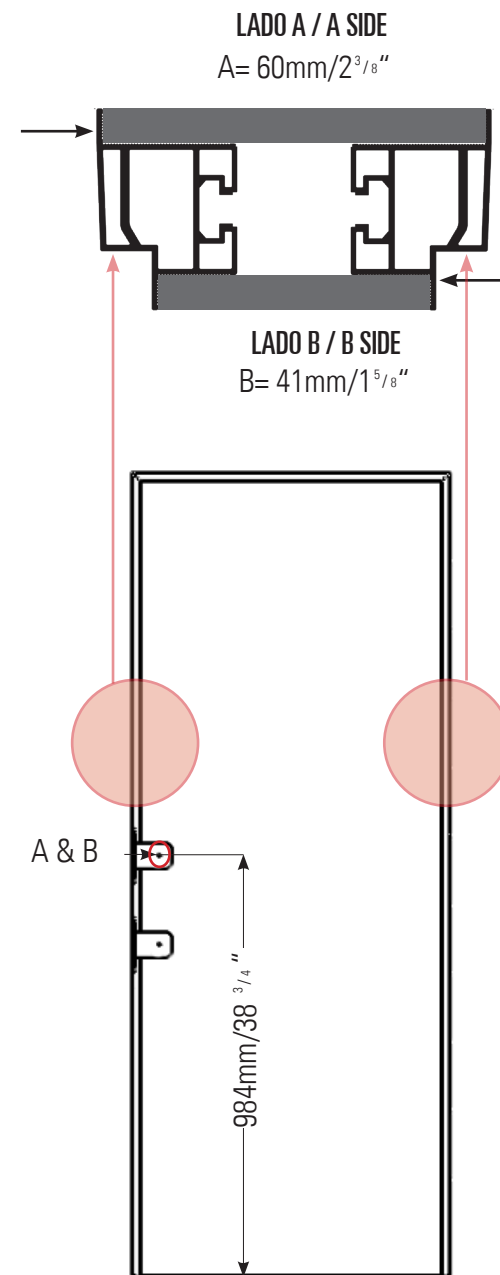
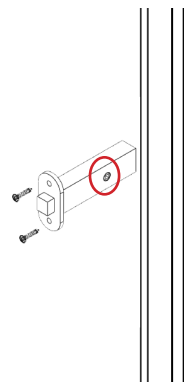

PASO 14 MEDIDA PARA TALADRO DE CONDENA

STEP 14 LOCK DRILL MEASURE

Tal como se puede apreciar en los perfiles verticales de la puerta, estos no son simétricos a ambas caras, ver imagen:

Debido a esto realizamos el agujero de la maneta teniendo en cuenta diferentes medidas según la cara donde taladramos.

Vertical door profiles are not symmetrical in both sides. see the attached image:

Take this fact into account, different measures according to the door side when you drill the handle hole.

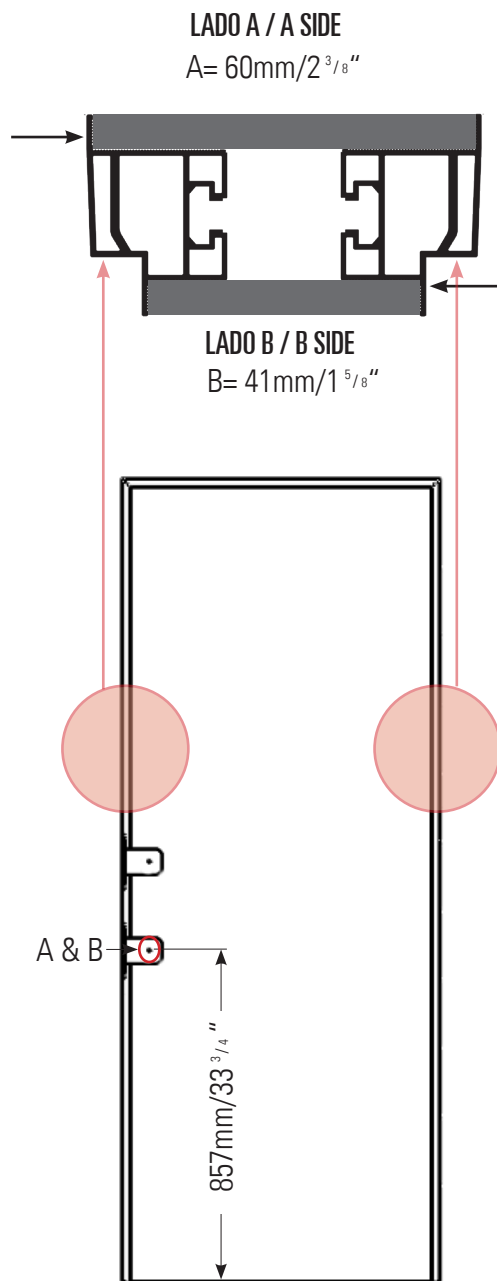
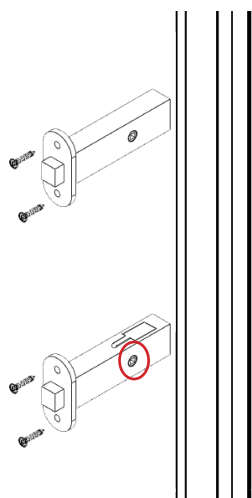

PASO 15 COLOCAR LA PUERTA EN EL MARCO

STEP 15 ASSEMBLY THE DOOR TO FRAME

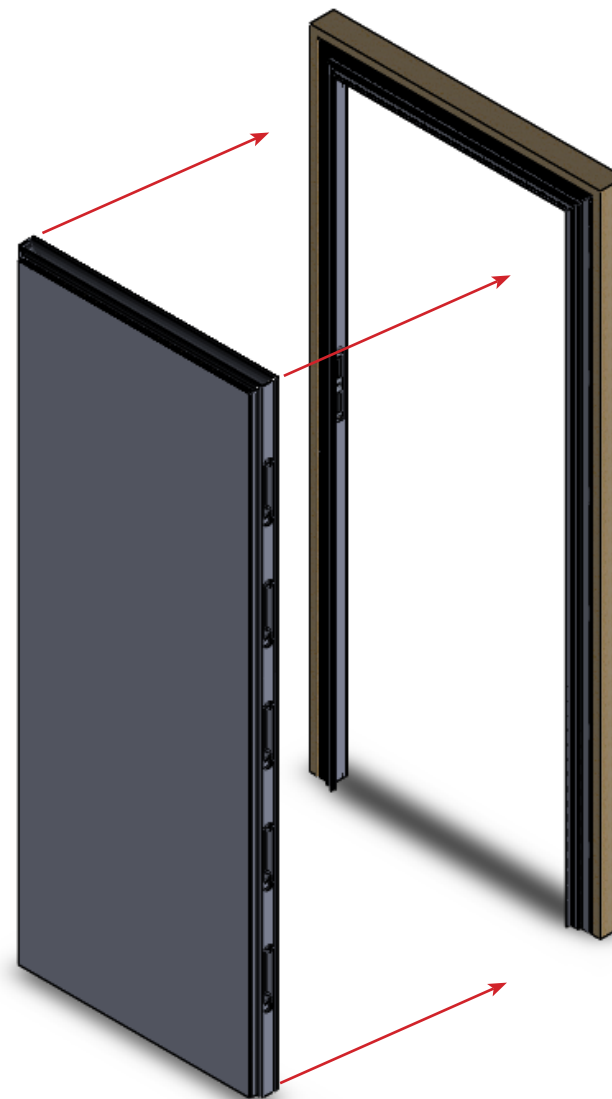

PASO 16 NIVELACION DE BISAGRAS

STEP 16 HINGES LEVELING ISNTRUCTIONS

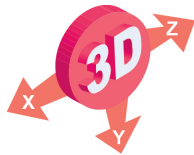
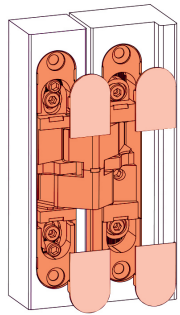

16.A) AJUSTE VERTICAL

16.A) VERTICAL LEVELING

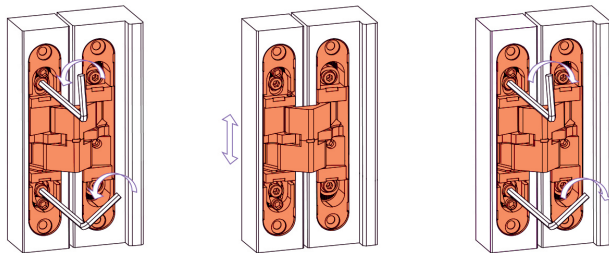
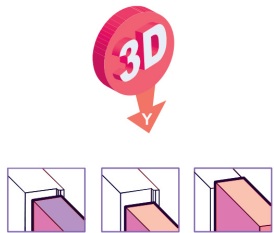

16.B) AJUSTE HORIZONTAL

16.B) HORIZONTAL LEVELING

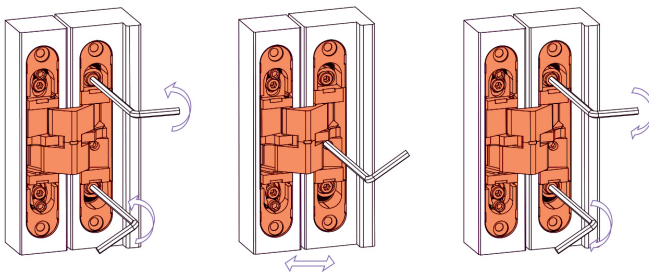
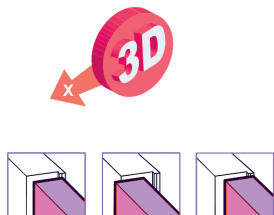

16.C) AJUSTE PROFUNDIDAD

16.C) DEEP LEVELING

