

TO RI NO

INSTRUCCIONES
DE MONTAJE

ADINOR S.L.



ÍNDICE

1

MADERA

1.1. SELECCIÓN DE GUÍA SUPERIOR E INFERIOR Y MONTAJE	4
1.2. POSICIONAMIENTO DE CARROS	6
1.3. COLOCACIÓN DE FRENOS Y AMORTIGUADORES DE CIERRE	8
1.4. MONTAJE DE PUERTAS	21

2

PERFILERÍA ALUMINIO ALUMINIUM FRAME

2.1. PARA PERFILERÍA ALUMINIO 10-11mm.	22
2.1.1. SELECCIÓN DE GUÍA SUPERIOR E INFERIOR Y MONTAJE	22
2.1.2. POSICIONAMIENTO DE CARROS	22
2.1.3. MONTAJE MARCO DE ALUMINIO	24
2.2. PARA PERFILERÍA ALUMINIO 19mm.	28
2.2.1. SELECCIÓN DE GUÍA SUPERIOR E INFERIOR Y MONTAJE	28
2.2.2. POSICIONAMIENTO DE CARROS	28
2.3. COLOCACIÓN DE FRENOS Y AMORTIGUADORES PARA PERFILERÍA ALUMINIO 10-11mm / 19mm	30

1.1. SELECCIONAR GUÍA SUPERIOR E INFERIOR Y MONTAJE

GS28-30mm.
GUÍA SUPERIOR
REFORZADA 28-30mm.
 28-30mm. HEAVY DUTY

Esesor tablero 28-30mm.
 Para perfilera aluminio 10-11mm.

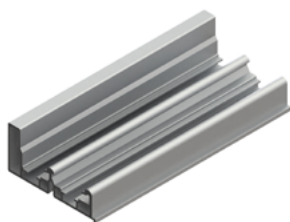

GS28-30mm.
GUÍA SUPERIOR
28-30mm.
 28-30mm. UPPER RAIL

Esesor tablero 28-30mm.
 Para perfilera aluminio 10-11mm.



GS25mm.
GUÍA SUPERIOR
25mm.
 25mm. UPPER RAIL

Esesor tablero 25mm.
 Para perfilera aluminio 19mm.



GS22mm.
GUÍA SUPERIOR
22mm.
 22mm. UPPER RAIL

Esesor tablero 22mm.

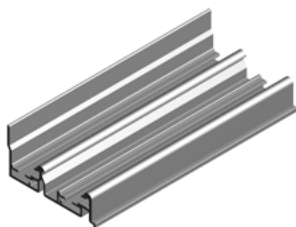

GS18-19mm.
GUÍA SUPERIOR
18-19mm.
 18-19mm. UPPER RAIL

Esesor tablero 18-19mm.

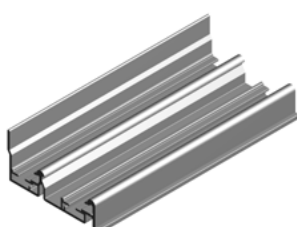

GI18-30mm.
GUÍA INFERIOR
18-30mm.
 LOWER RAIL FOR
 18-30mm. BOARD

Para todos los espesores.



Grueso puerta / Chip Board Thickness

18, 19, 22, 25, 28, 30

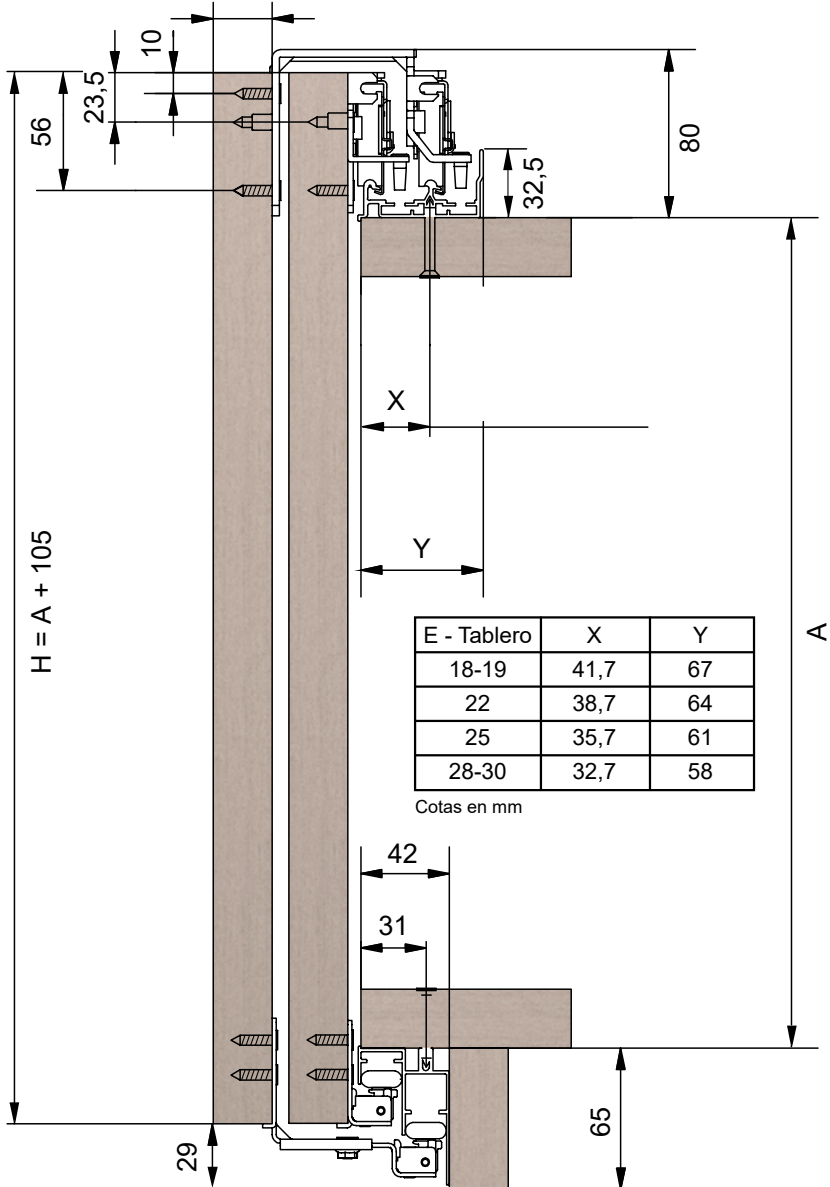

1

1.2. POSICIONAMIENTO DE CARROS

CARRO INFERIOR EXTERIOR

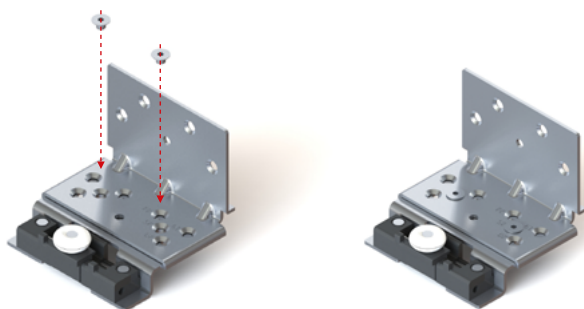

CERRADO

ABIERTO

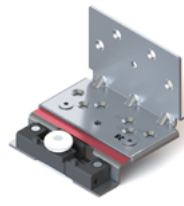
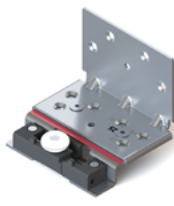
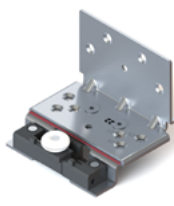
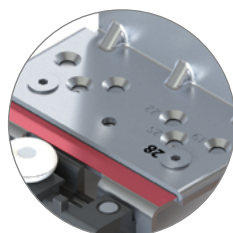
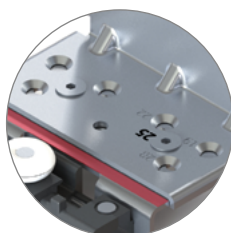
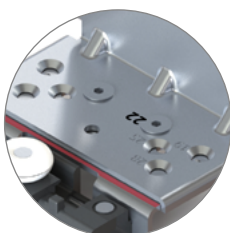
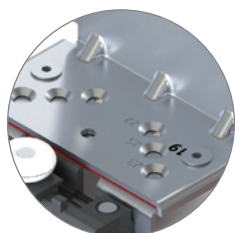

Espesor tablero 18-19mm.

Espesor tablero 22mm.

Espesor tablero 25mm.

Espesor tablero 28-30mm.

CARRO SUPERIORES (ANTIDESCARRILAMIENTO)

POSICIÓN DE MONTAJE

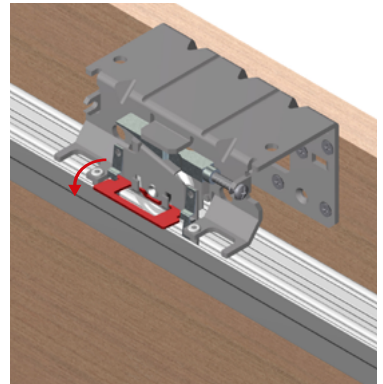
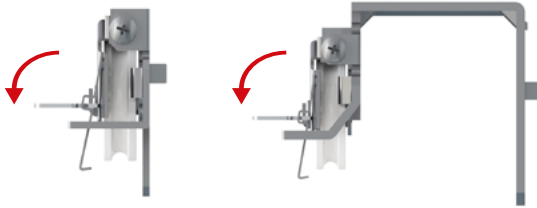

Detalle de la pestaña en montaje.

POSICIÓN ANTIDESCARRILAMIENTO

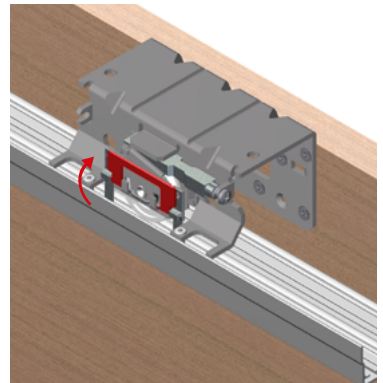
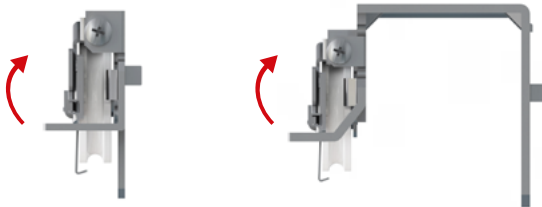

Detalle de la pestaña en antidescarrilamiento.

PARA PODER MONTAR / DESMONTAR LAS PUERTAS, ES NECESARIO QUE LOS CARROS ESTÉN EN POSICIÓN DE MONTAJE. DE OTRA MANERA, NO SERÍA POSIBLE DESMONTAR LAS PUERTAS.

1

1.3. COLOCACIÓN DE FRENOS Y AMORTIGUADORES

FRENO ESTÁNDAR

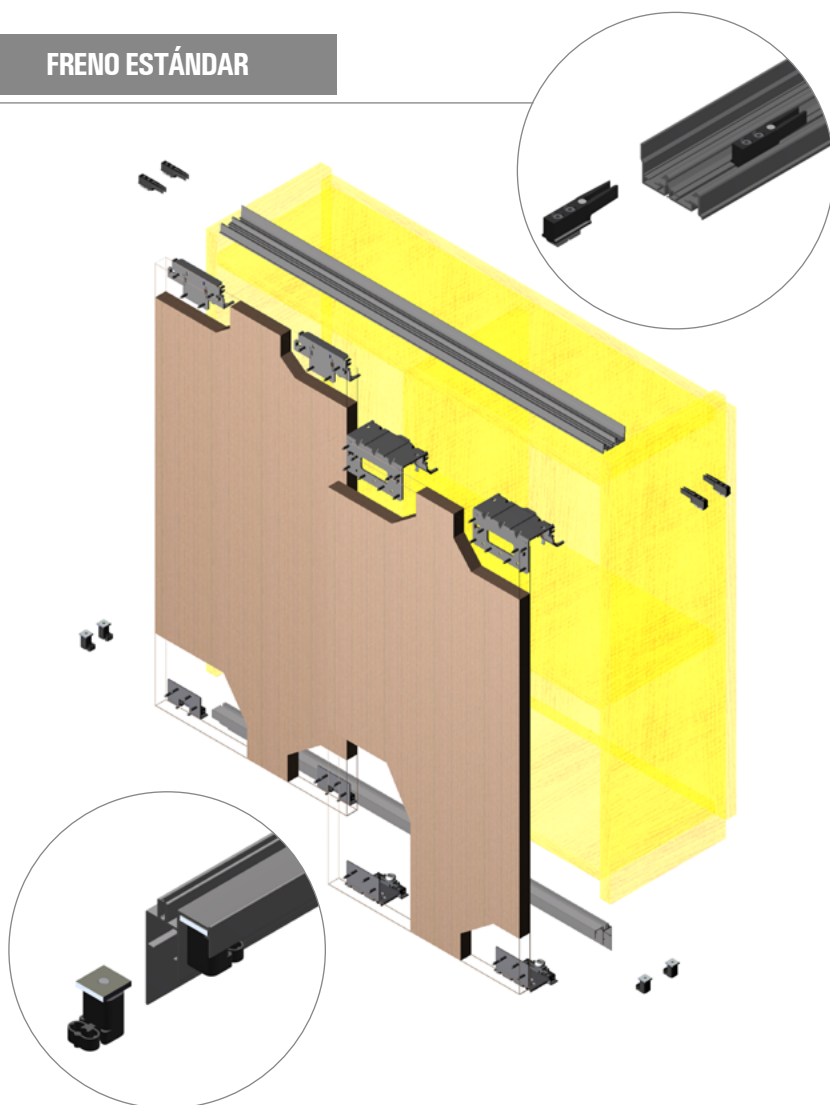

MONTAJE EN PUERTA INTERIOR

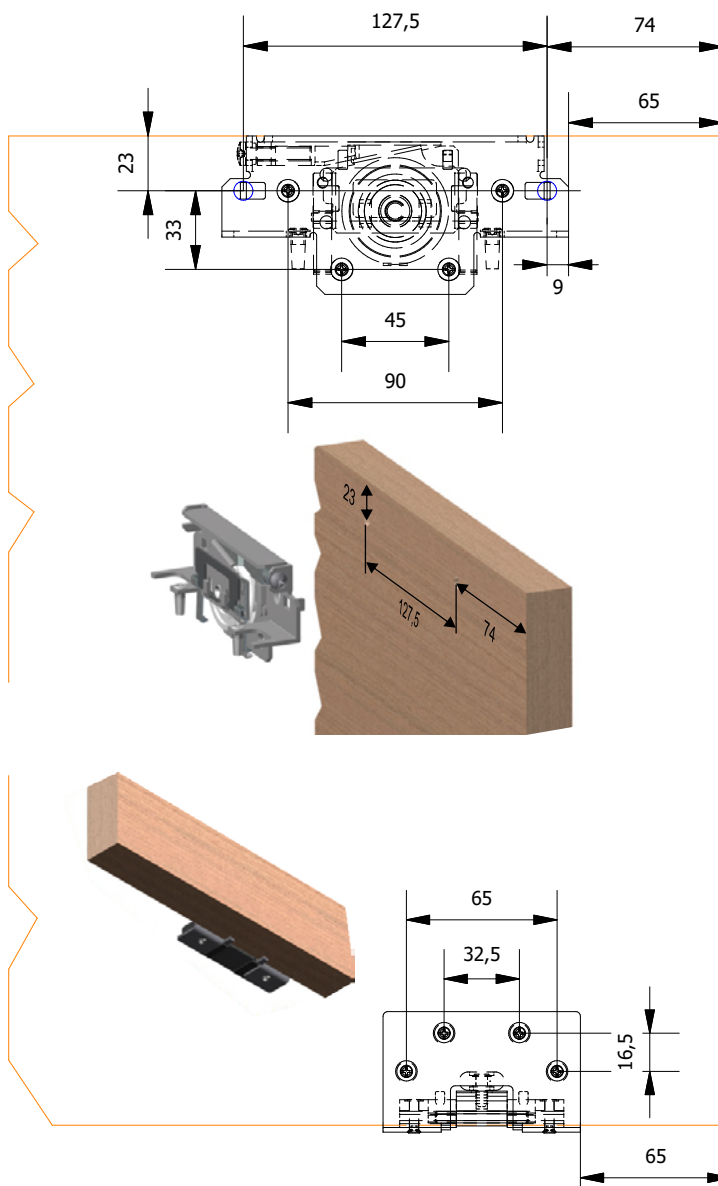

MONTAJE EN PUERTA EXTERIOR

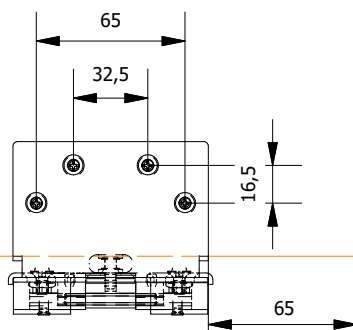
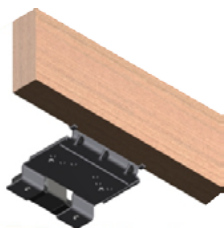
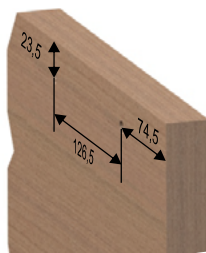
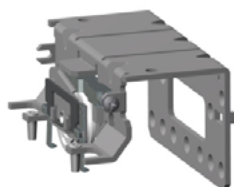
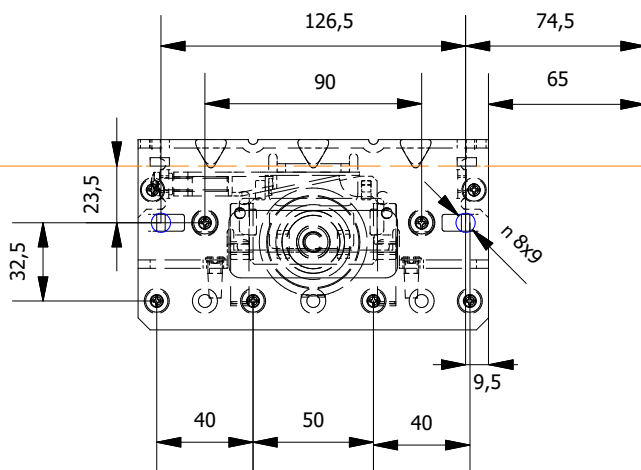

MONTAJE DE AMORTIGUADORES

Dos Puertas / Two Doors

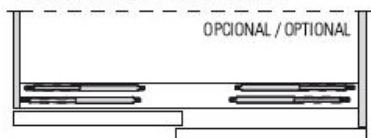

Tres Puertas / Three Doors

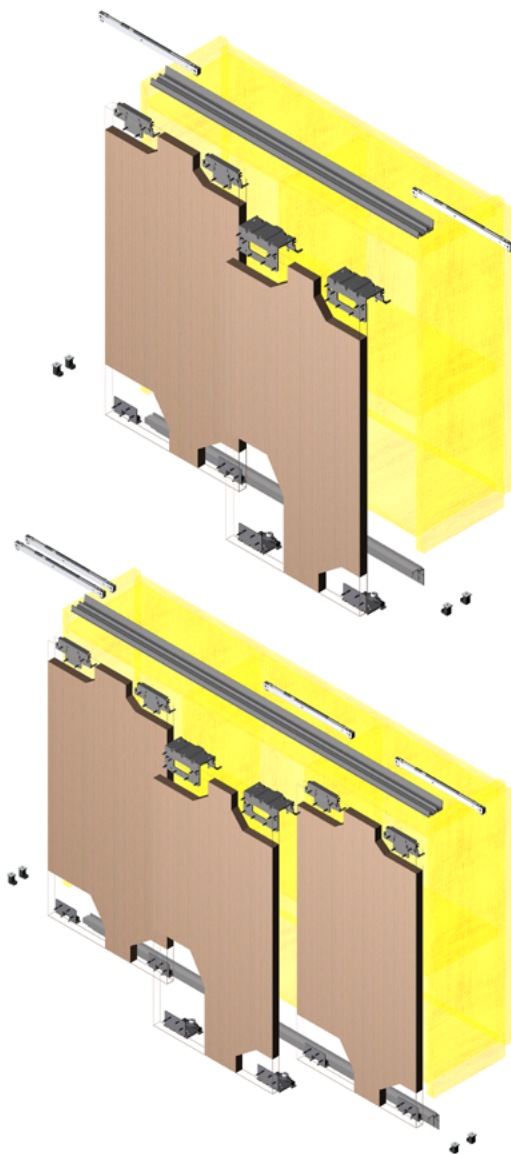
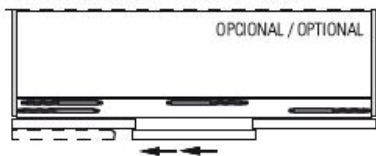

1

AMORTIGUADOR 25 Y 40 KG (FIG. A1)



FIGURA A1.

CARROS EN PUERTA INTERIOR

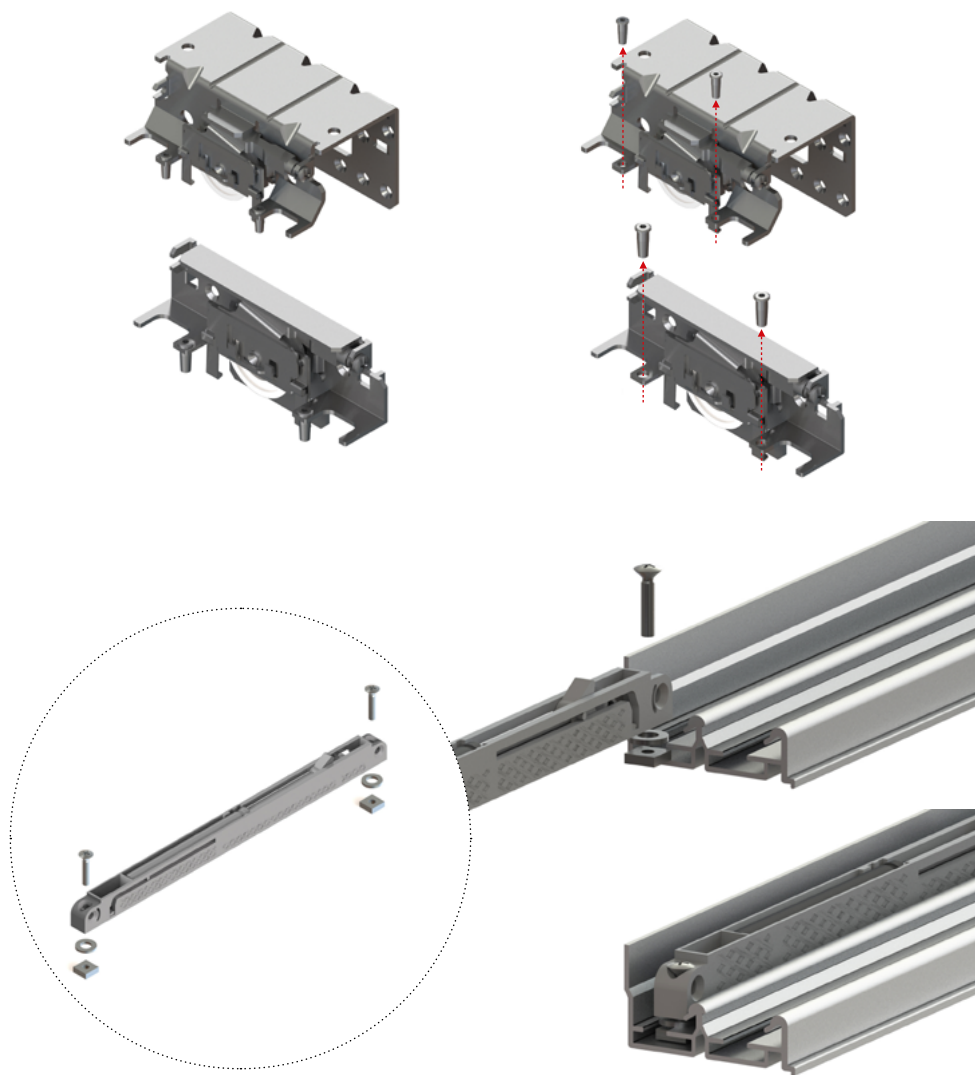

FIGURA A2.

CARROS EN PUERTA EXTERIOR

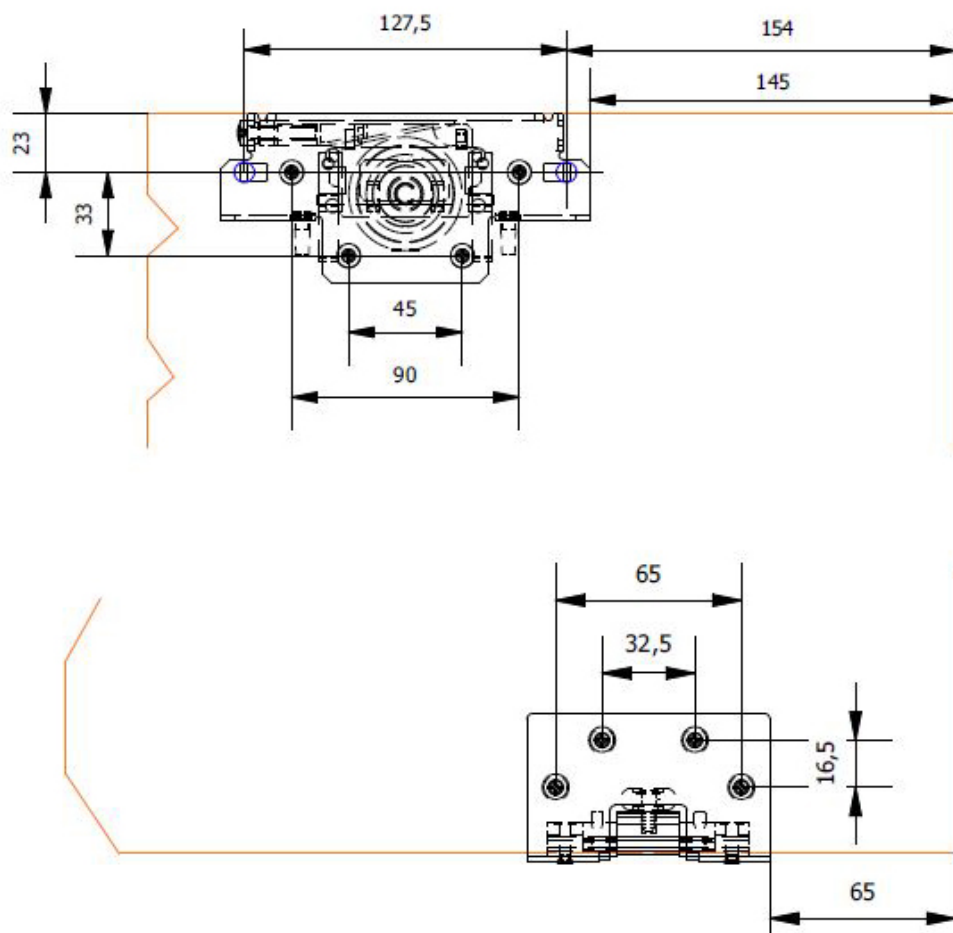

FIGURA A3.

AMORTIGUADOR 60 Y 80 KG (FIG. B1, B2, B3)

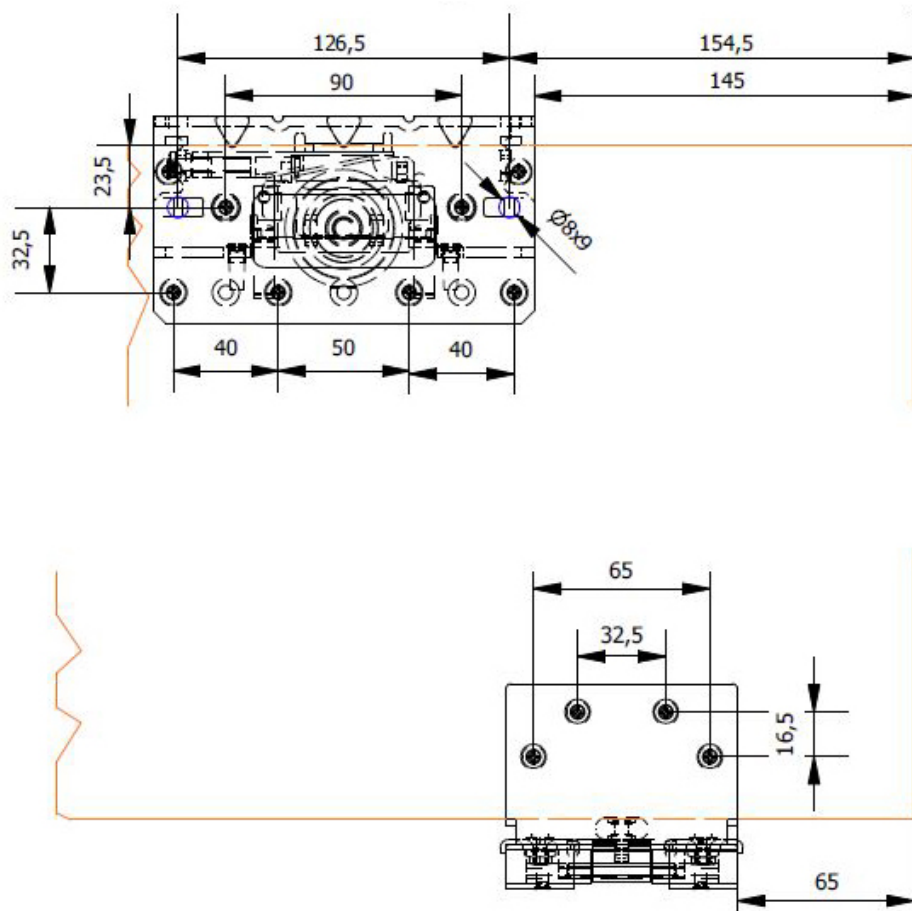

FIGURA B1.

CARROS EN PUERTA INTERIOR

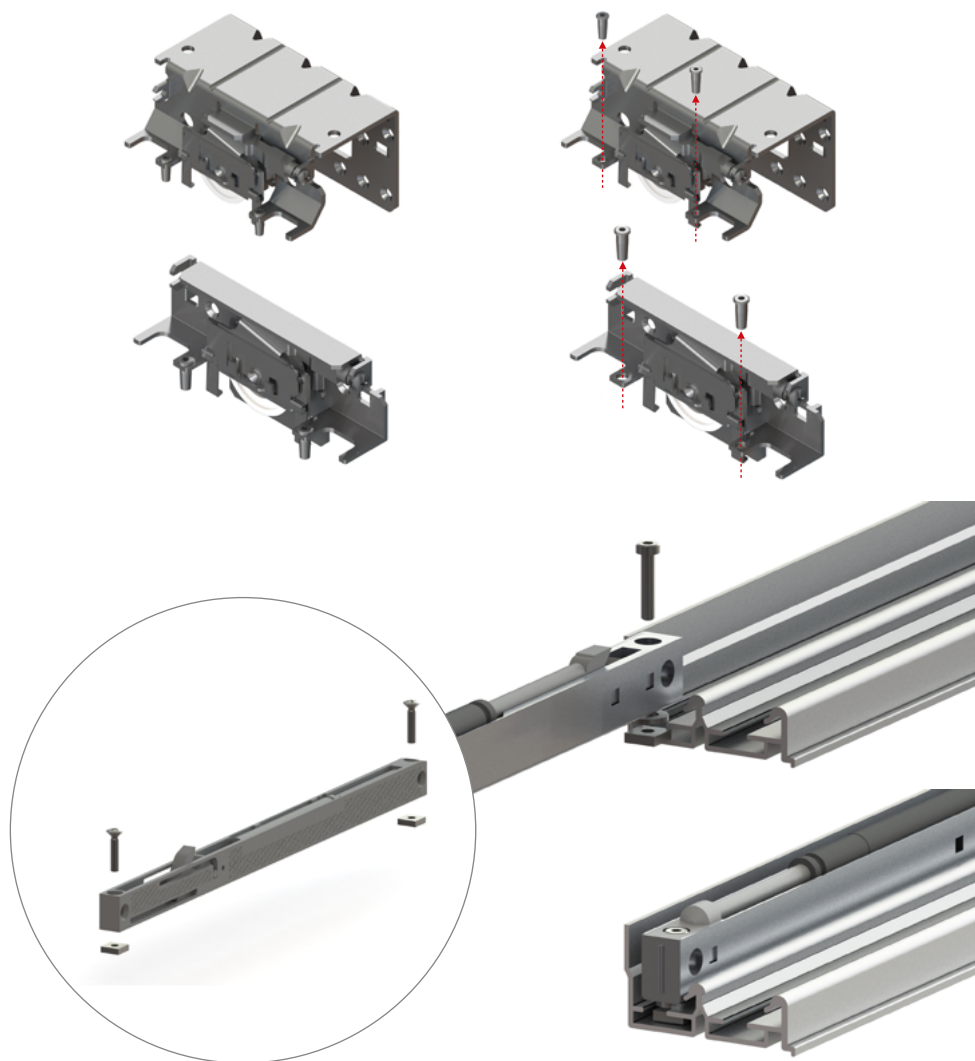

FIGURA B2.

CARROS EN PUERTA EXTERIOR

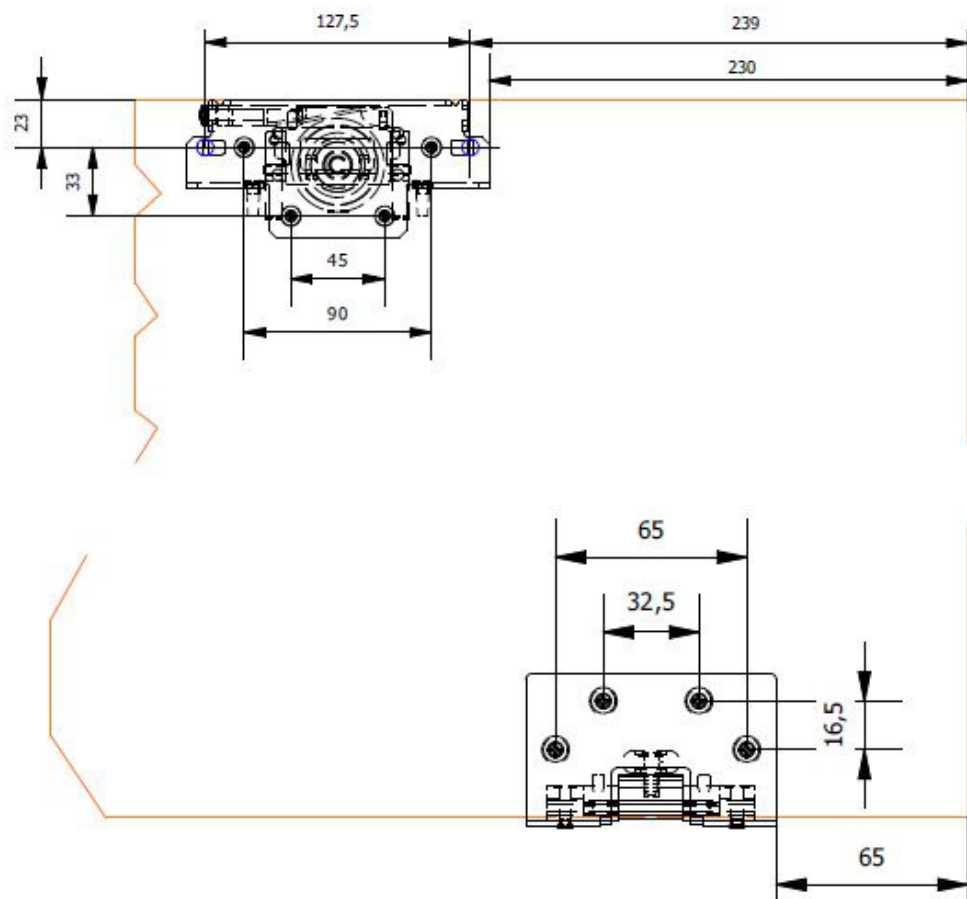

FIGURA B3.

1

AMORTIGUADOR INVERTIDO 25, 40 Y 60 KG ESPECIAL PARA PUERTA ESTRECHAS (FIG. C1, C2, C3)

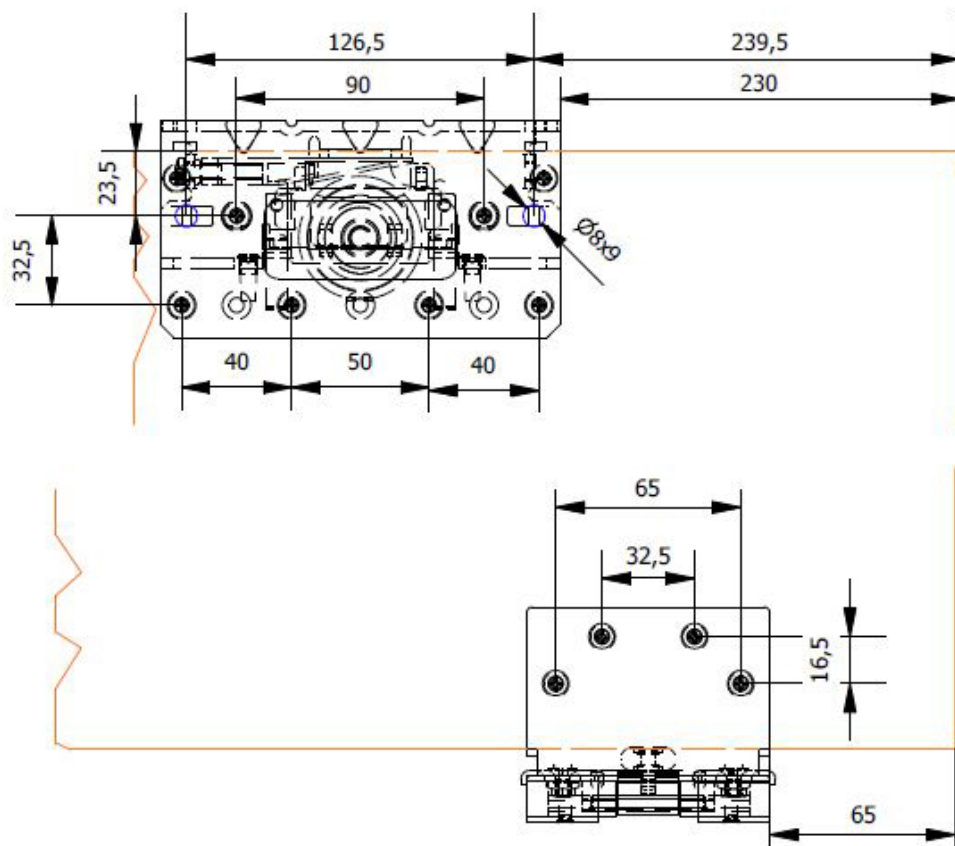

FIGURA C1.

CARROS EN PUERTA INTERIOR

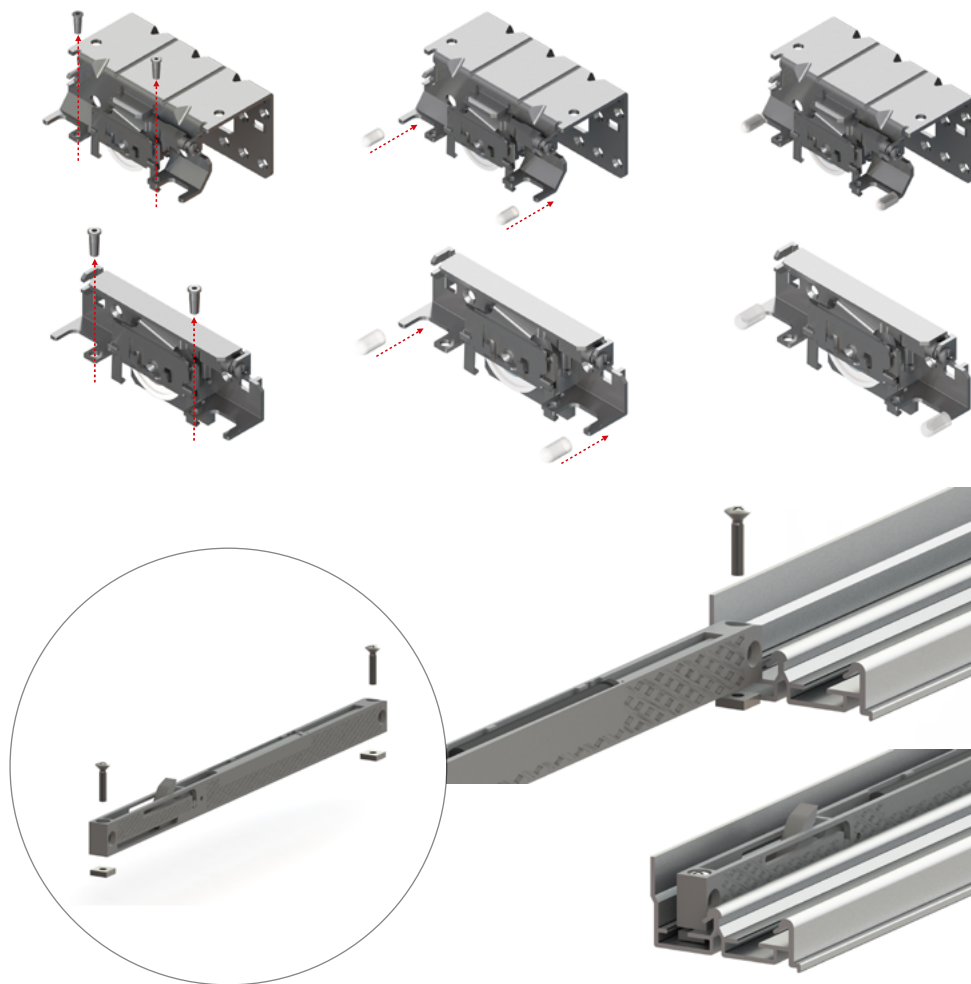

FIGURA C2.

CARROS EN PUERTA EXTERIOR

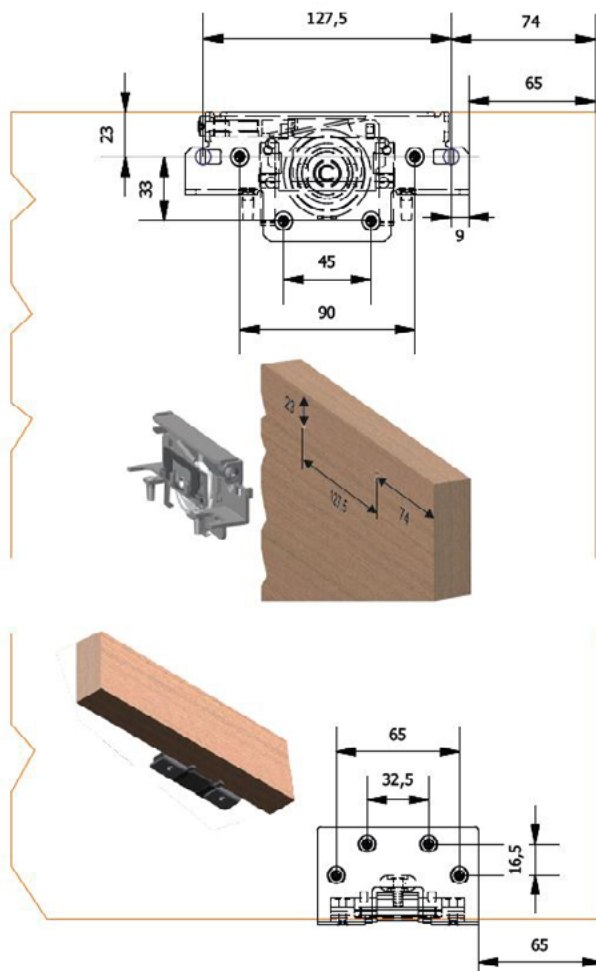

FIGURA C3.

1.4. MONTAJE DE PUERTAS

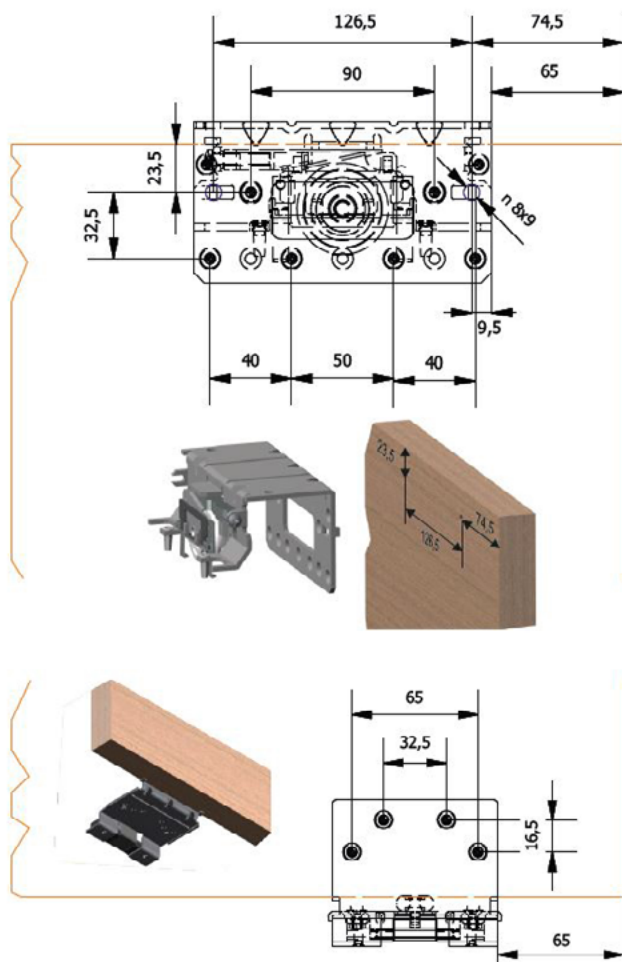
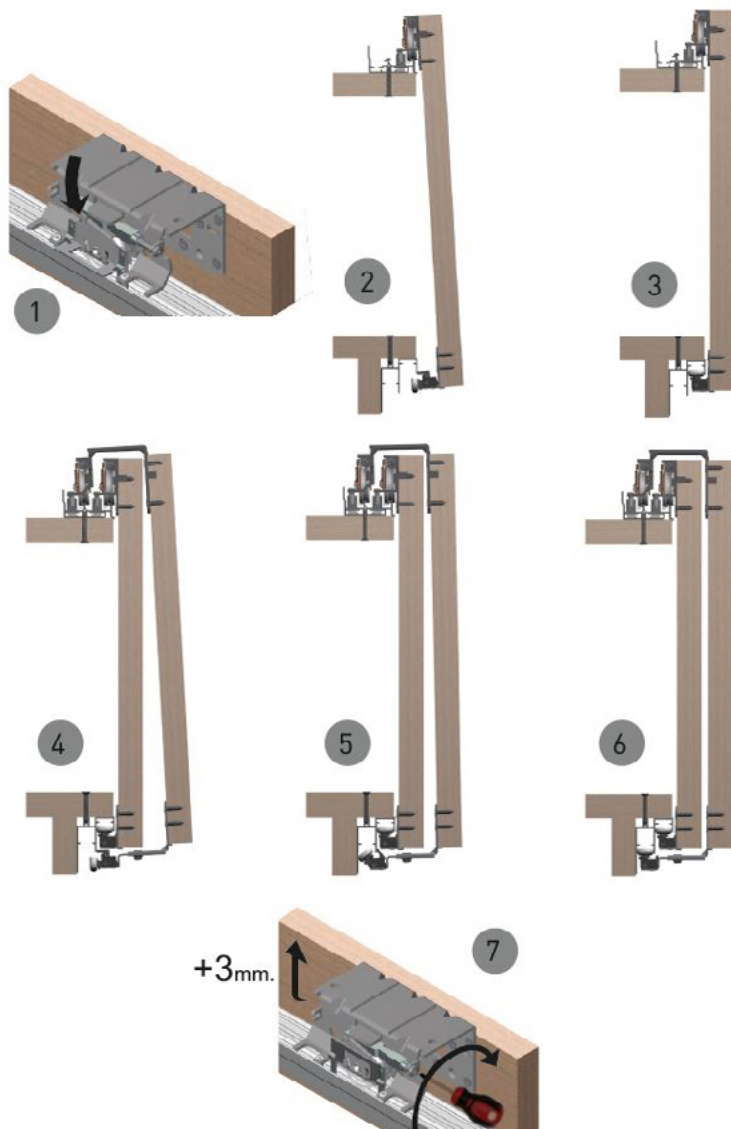

2.1. PARA PERFILERÍA ALUMINIO 10-11mm

2.1.1. SELECCIONAR GUÍA SUPERIOR E INFERIOR Y MONTAJE

GS28-30mm.
GUÍA SUPERIOR
REFORZADA 28-30mm.
28-30mm. HEAVY DUTY

Esesor tablero 28-30mm.
Para perfilera aluminio 10-11mm.

GS28-30mm.
GUÍA SUPERIOR
28-30mm.
28-30mm. UPPER RAIL

Esesor tablero 28-30mm.
Para perfilera aluminio 10-11mm.

G118-30mm.
GUÍA INFERIOR
18-30mm.
LOWER RAIL FOR
18-30mm. BOARD

Para todos los espesores.

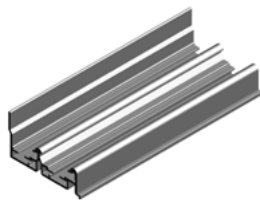
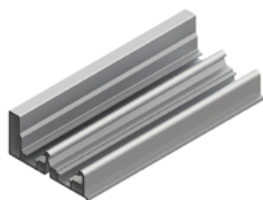

2.1.2. POSICIONAMIENTO DE CARROS

MISMO PROCEDIMIENTO DE POSICIONAMIENTO DE CARROS QUE PARA MADERA **SÓLO CON ATORNILLADO EN EL ORIFICIO 28mm.**

CARRO INFERIOR EXTERIOR

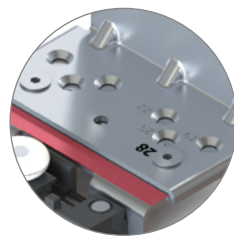
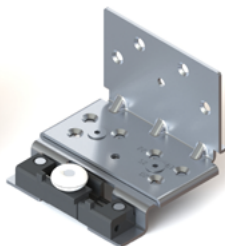
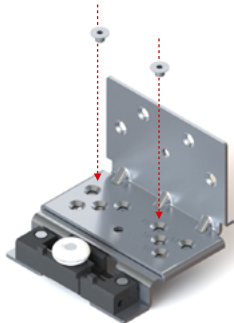

Esesor tablero 28-30mm.

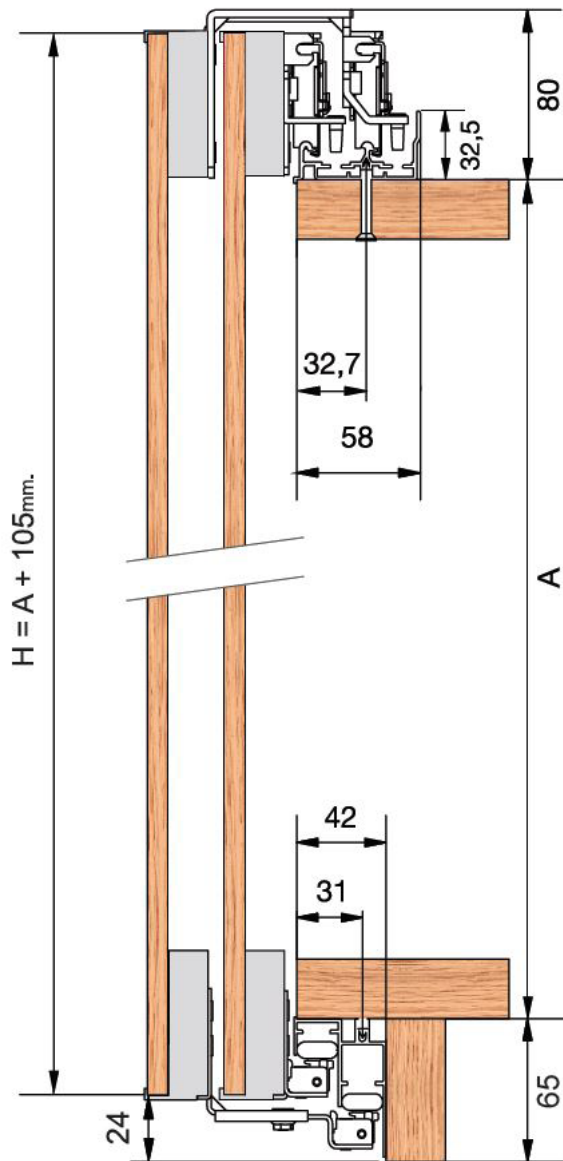

2

2.1.3. MONTAJE MARCO DE ALUMINIO

A. MONTAJE TENSOR UNIÓN

1

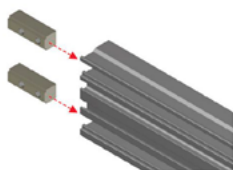

2

Enrasar con el perfil horizontal
Perpendicular joint must not protrude out of the horizontal profile

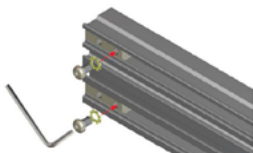

3

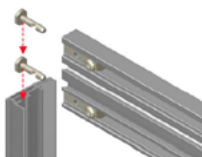

4

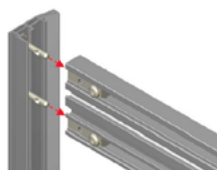

5

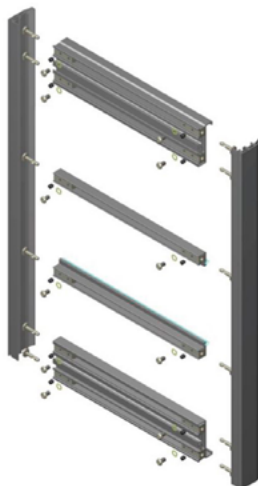
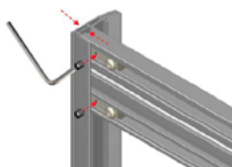

B. TORNILLERÍA CARROS

2 ud. tornillo M4x8mm
2 ud. tuerca 10x10x4mm

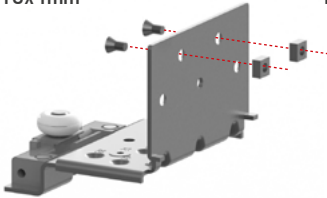

4 ud. tornillo M4x12mm
4 ud. tuerca 10x10x10mm

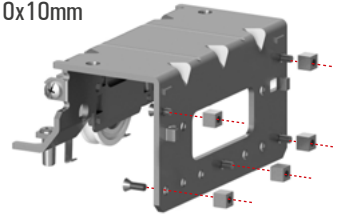

2 ud. tornillo M4x8mm
2 ud. tuerca 10x10x4mm

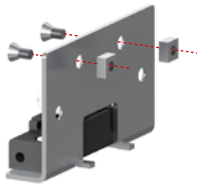

2 ud. tornillo M4x8mm
2 ud. tuerca 10x10x4mm
2 ud. tornillo M4x12mm
2 ud. tuerca 10x10x10mm

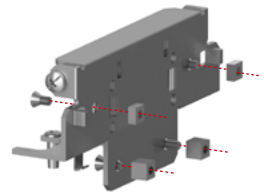

C. TORNILLERÍA CARROS-GUÍA

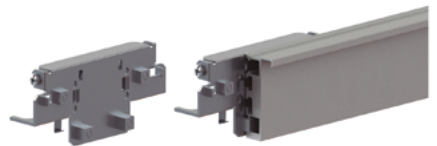
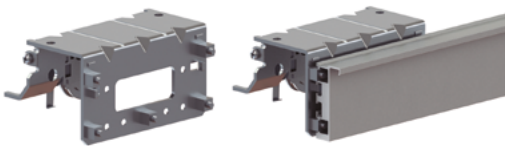

2

**Puerta todo Cristal
con Perfiles H**
Glass Door with
H Profiles

$$Z = \frac{H - 6 - (4 \times nT)}{nT + 1}$$

**Puerta todo Cristal
con Tensores Cristal**
Glass Door with
Straightener Profiles

$$Z = H - 6$$

**Puerta todo Madera
con Tensores Madera**
Wood Door with
Straightener Profiles

$$Z = H - 4$$

**Puerta todo Madera
con Perfiles H**
Wood Door with
H Profiles

$$Z = \frac{H - 4 - (2 \times nT)}{nT + 1}$$

**Puerta Mixta Madera-
Cristal con Perfiles H**
Wood-Glass Door
with H Profiles

$$Z = \frac{H - 4 - (3 \times nT)}{nT + 1}$$

nT = número de travesaños
(2 en los ejemplos).

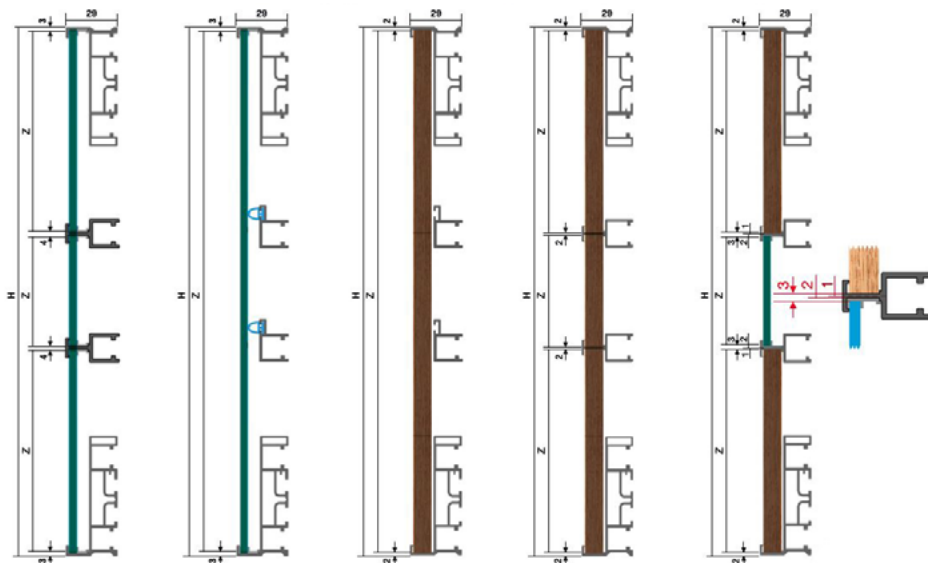

Cálculo ancho de puertas / Board width
 Armario 2 puertas / 2 doors wardrobe

$$P = \frac{L}{2} + 5\text{mm.}$$

Cálculo ancho de puertas / Board width
 Armario 3 puertas / 3 doors wardrobe

$$P = \frac{L}{3} + 7\text{mm.}$$

Cálculo ancho de puertas / Board width
 Armario 4 puertas / 4 doors wardrobe

$$P = \frac{L}{4} + 7\text{mm.}$$

Anchura panel Cristal
 Glass Width

$$P = 16\text{mm.}$$

Anchura panel Madera
 Board Width

$$P = 14\text{mm.}$$

Longitud Perfil Faldón Superior / Inferior
 Upper and Lower Connection Torino Profile Width

Longitud Perfil H
 Torino H Profile Width

Longitud Tensor Madera / Cristal
 Straightener Torino Glass / Wood Profile Width

$$P = 21\text{mm.}$$

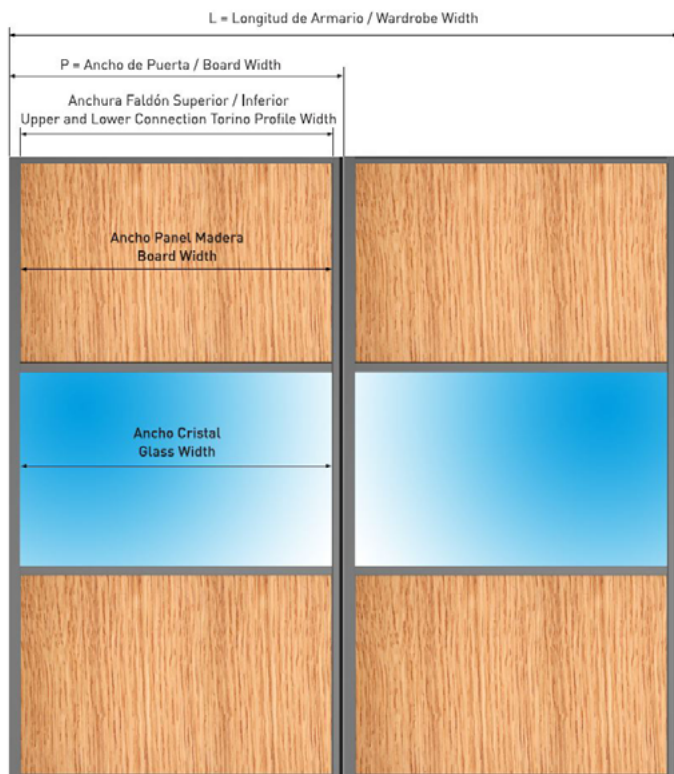

2

2.2. PARA PERFILERÍA ALUMINIO 19 mm

2.2.1. SELECCIONAR GUÍA SUPERIOR E INFERIOR Y MONTAJE

GS25mm. GUÍA SUPERIOR 25mm.

25mm. UPPER RAIL

Espesor tablero 25mm.
Para perfilera aluminio 19mm.

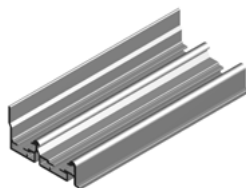

G118-30mm. GUÍA INFERIOR 18-30mm.

LOWER RAIL FOR
18-30mm. BOARD

Para todos los espesores.

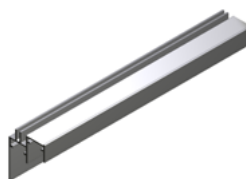

2.2.2. POSICIONAMIENTO DE CARROS

MISMO PROCEDIMIENTO DE POSICIONAMIENTO DE CARROS QUE
PARA MADERA SÓLO CON ATORNILLADO EN EL ORIFICIO 25mm.

CARRO INFERIOR EXTERIOR

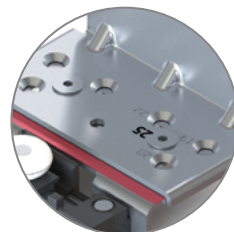
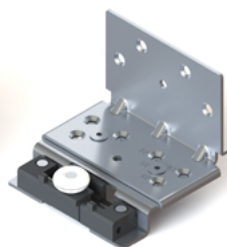
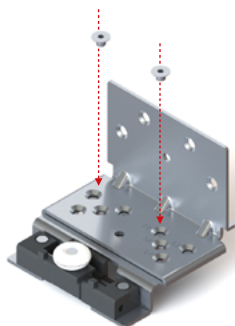

Espesor tablero 25mm.

Grueso puerta / Chip Board Thickness

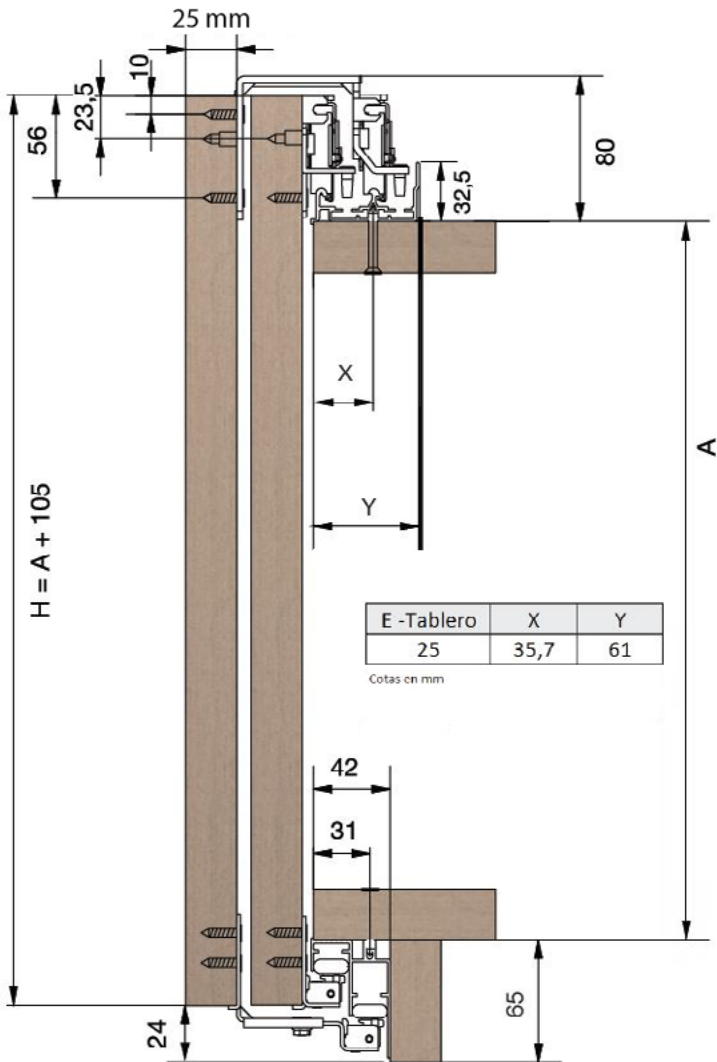

2

1.3. COLOCACIÓN DE FRENOS Y AMORTIGUADORES

FRENO ESTÁNDAR

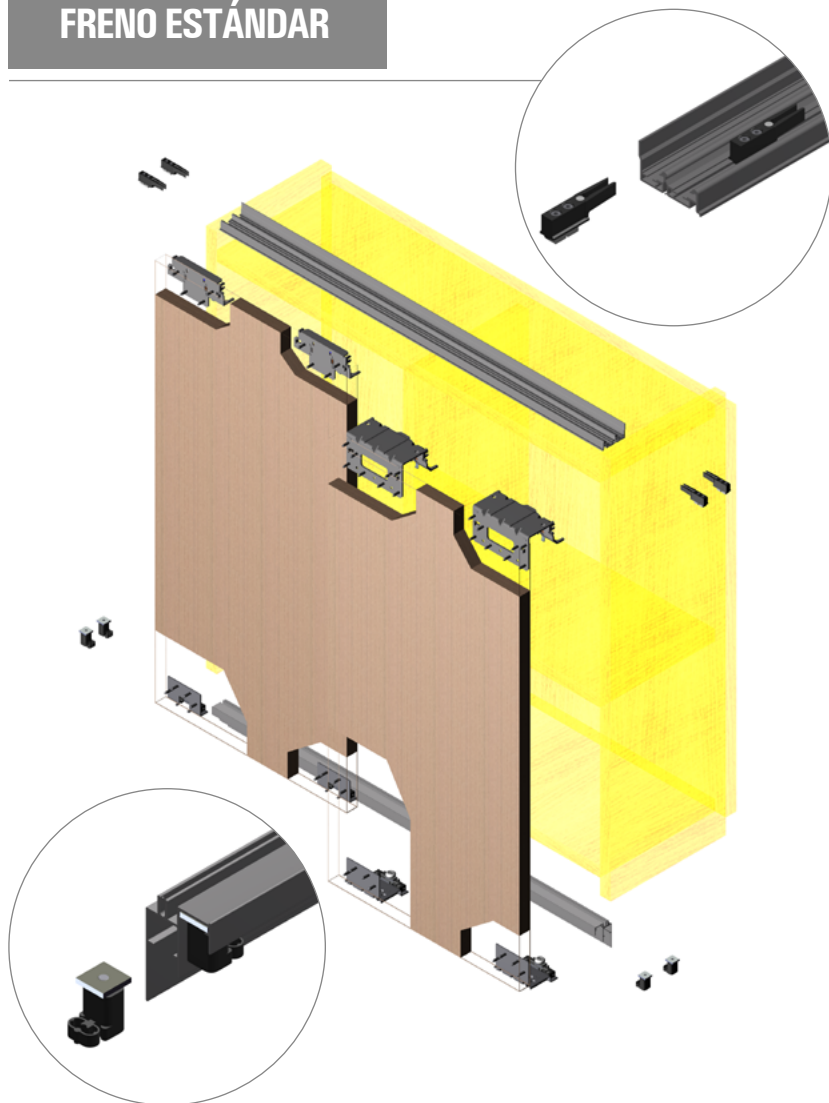

POSICIÓN CARRO SUPERIOR INTERIOR

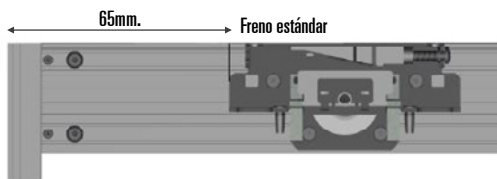

POSICIÓN CARRO SUPERIOR EXTERIOR

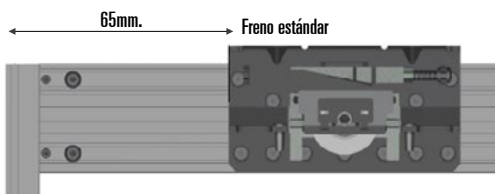

POSICIÓN CARRO INFERIOR EXTERIOR

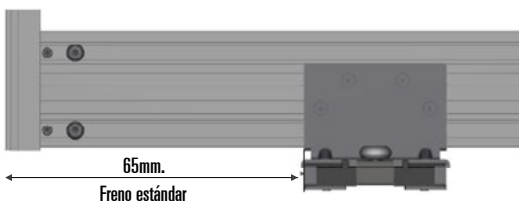

POSICIÓN CARRO INFERIOR INTERIOR

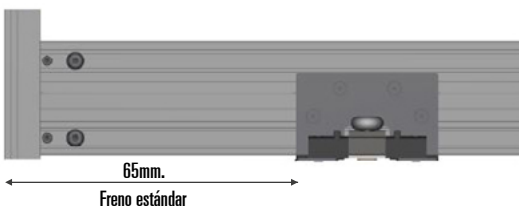

2

MONTAJE DE AMORTIGUADORES

Dos Puertas / Two Doors

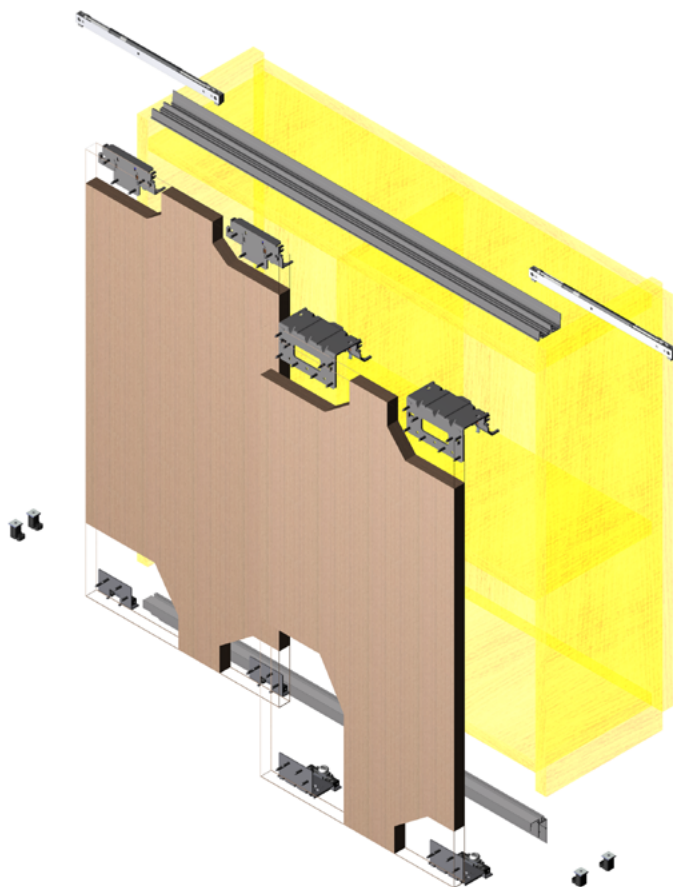
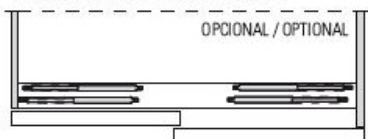

Tres Puertas / Three Doors

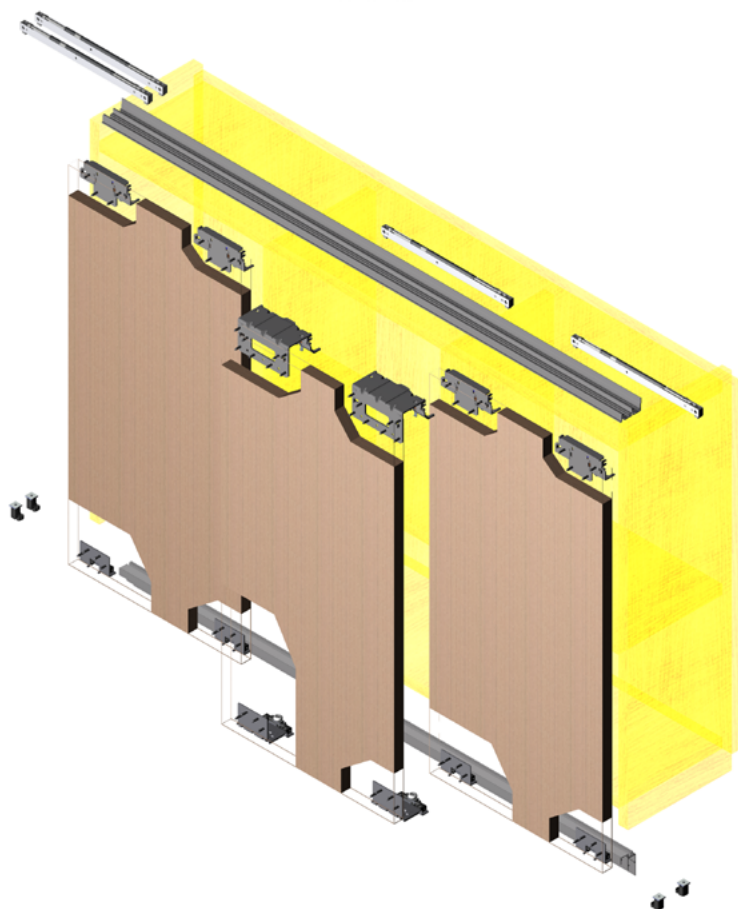
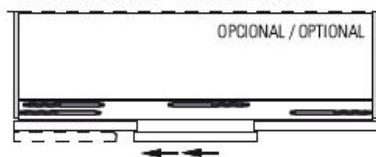

2

AMORTIGUADOR 25 Y 40 KG (FIG. A1)



FIGURA A1.

POSICIÓN CARRO SUPERIOR INTERIOR



POSICIÓN CARRO SUPERIOR EXTERIOR

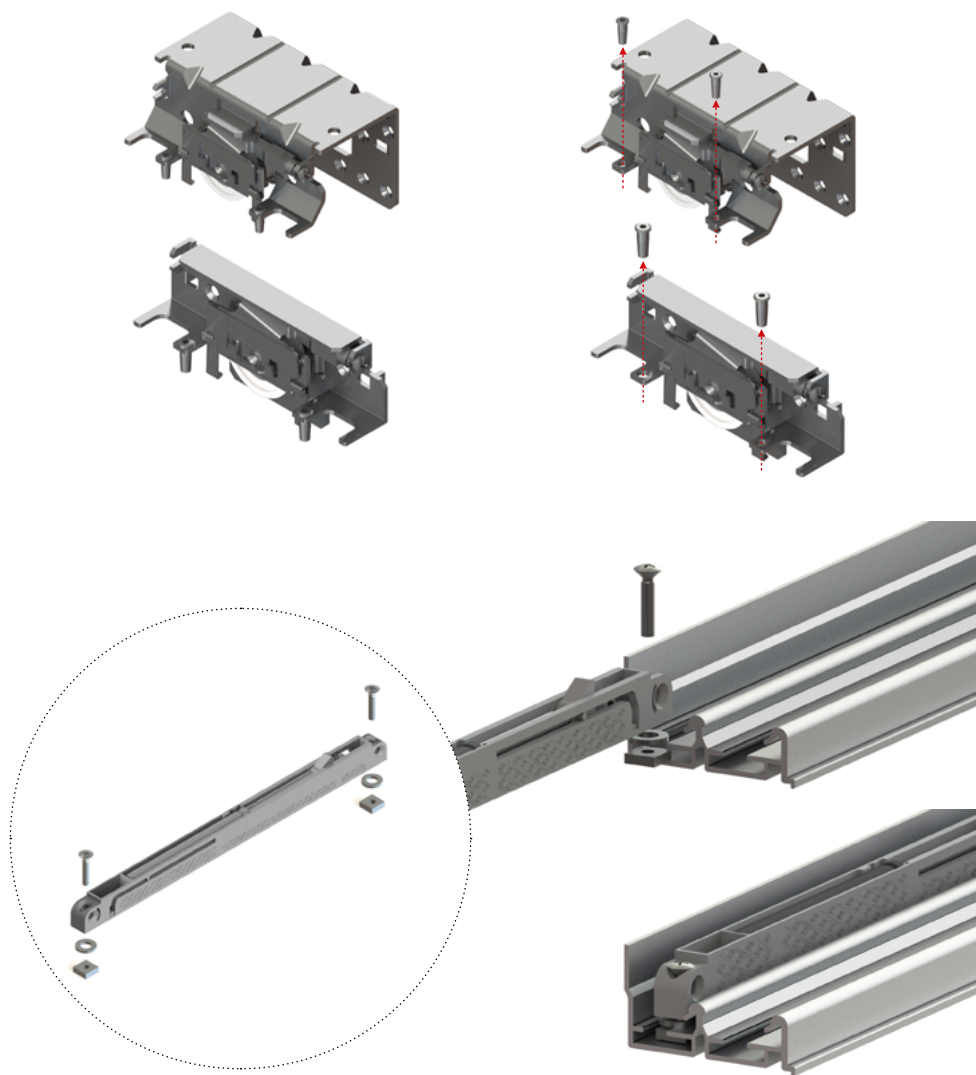
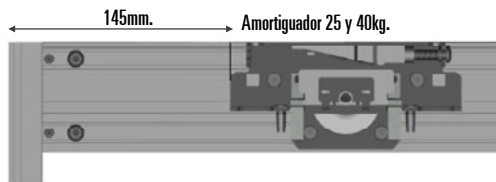
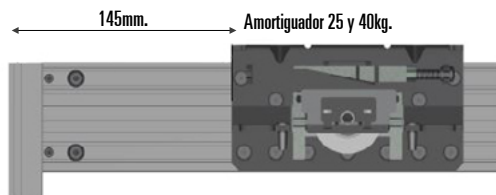

POSICIÓN CARRO INFERIOR EXTERIOR

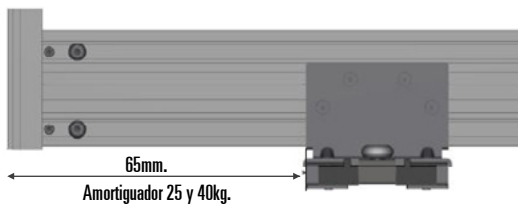

POSICIÓN CARRO INFERIOR INTERIOR

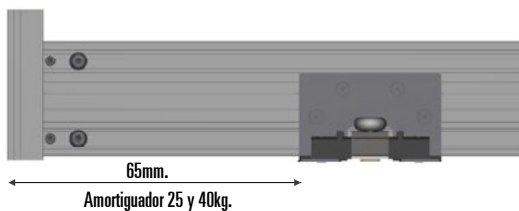

2

AMORTIGUADOR 60 Y 80 KG (FIG. B1) 60 & 80 KG SOFT-CLOSING (PIC.B1)



FIGURA B1.

POSICIÓN CARRO SUPERIOR INTERIOR



POSICIÓN CARRO SUPERIOR EXTERIOR

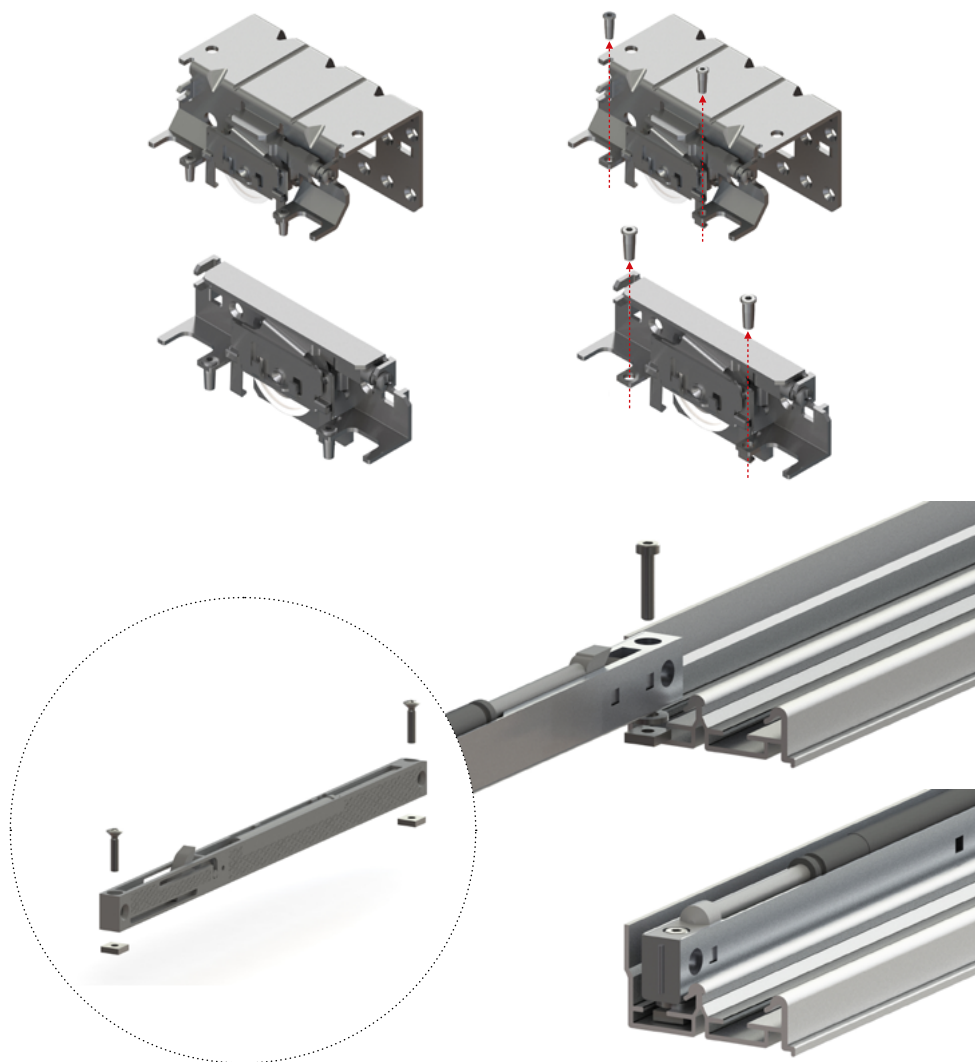
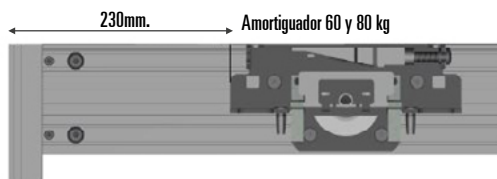
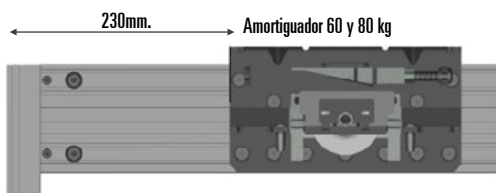

POSICIÓN CARRO INFERIOR EXTERIOR

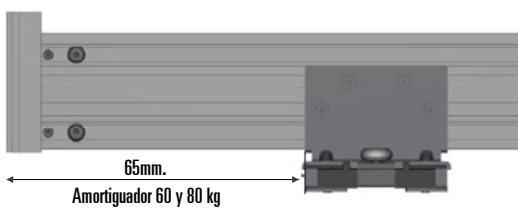

POSICIÓN CARRO INFERIOR INTERIOR

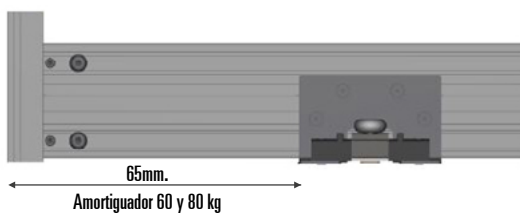

2

AMORTIGUADOR INVERTIDO 25, 40 Y 60 KG ESPECIAL PARA PUERTAS ESTRECHAS (FIG. C1)



FIGURA C1.

POSICIÓN CARRO SUPERIOR INTERIOR



POSICIÓN CARRO SUPERIOR EXTERIOR

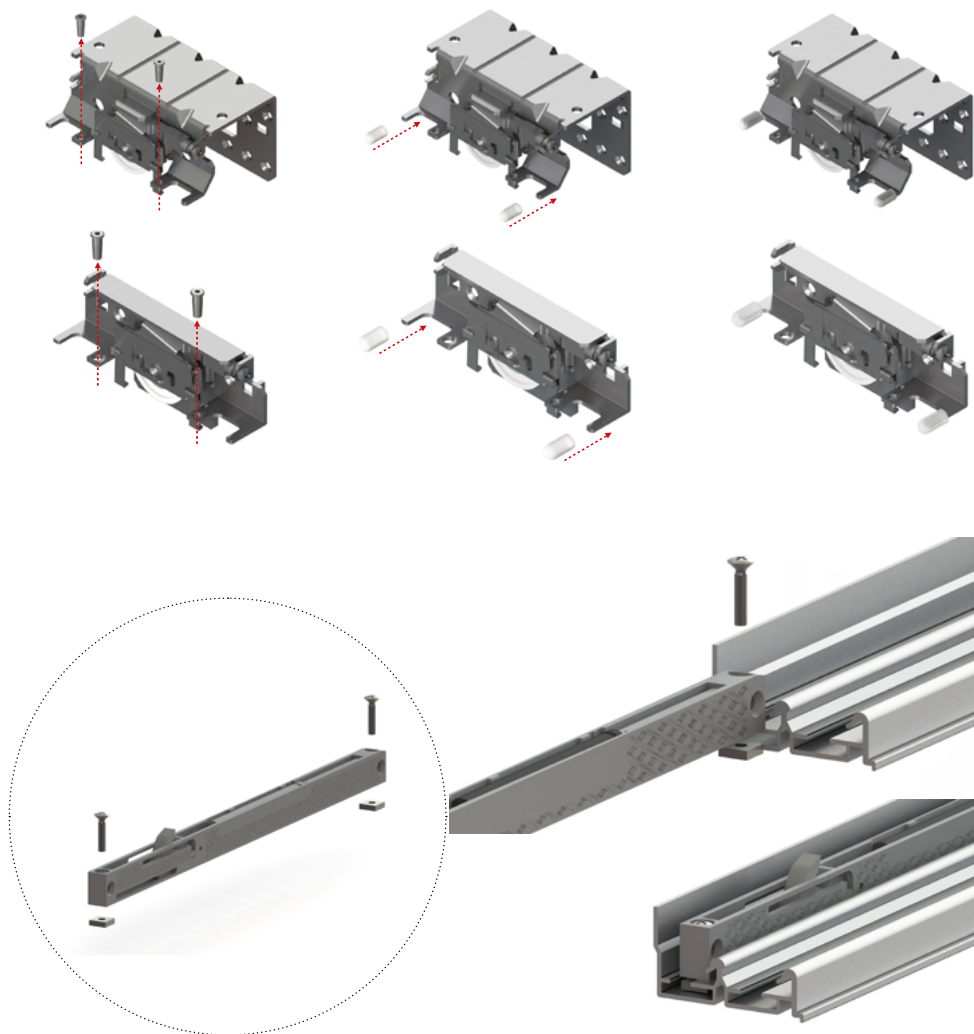
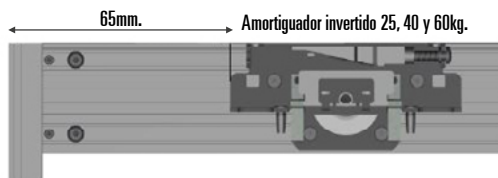
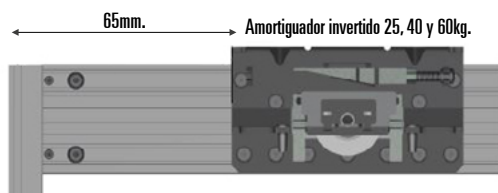

POSICIÓN CARRO INFERIOR EXTERIOR

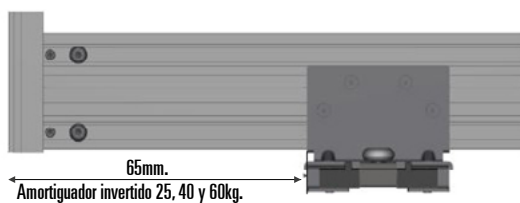

POSICIÓN CARRO INFERIOR INTERIOR

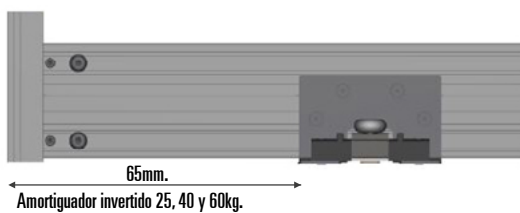



TO RI NO

INSTRUCCIONES
DE MONTAJE

ADINOR S.L.

Avda. Gijón, 90-92
47009 VALLADOLID
-ESPAÑA-

Telf.: +34 983 267 512
+34 983 255 304
Fax: +34 983 267 508

www.adinor.info
adinor@adinorsl.es